



National Fire  
Equipment Ltd.

Providing fire protection  
solutions since 1959

## High Pressure CO2 Fire Protection Systems

### Proven reliability for mission-critical applications

Every enterprise has equipment and facilities that are vital to its operation. Business would be seriously affected if these were destroyed by fire. In many cases valuable assets should not be protected by water or other similar extinguishing agents, as these types of agents often are unable to reach inaccessible parts of the hazard. They can also cause considerable damage even in excess of that done by the fire itself.

Carbon dioxide is a reliable, versatile and efficient fire fighting agent. It has provided decades of successful operation. It is a dry, inert, non-corrosive gas that will not damage equipment or materials or contaminate liquids or food. It does not leave any residue to clean-up, and as a result, business down-time is held to a minimum. In addition, carbon dioxide is a non-conductor of electricity, and can even be used without danger in spaces housing high voltage electrical equipment.



### Featuring innovative high-performance cylinder valves

- Patented cost-saving unibody design  
– does not have separate valve and discharge heads.



# Why CO2...

Carbon dioxide is a standard commercial product that is commonly used for carbonated beverages, for fast freezing food, for medical purposes, for purging pipes and tanks, as well as for extinguishing fires. It is readily available in most cities and seaports throughout the world. For more than 80 years carbon dioxide has been used for fire protection purposes. The NFPA standard for fire extinguishing systems was initiated in 1928, was first adopted in 1929. It has been revised approximately 26 times since, and represents the accumulated knowledge and experience of those who have designed and used CO2 systems for fire extinguishing purposes.



## Advantages of CO2 fire extinguishing systems

- A viable agent for the foreseeable future. No ban on its use.
- Is well established. Has been successfully used for 80 years.
- Is a standard commercial product with many other uses and as a result is readily available in most towns and cities around the world.
- Low agent cost. Beneficial when frequent recharging is a factor, such as with engine test cell protection.
- Installed system cost is lower when compared to clean agents.
- Is stable and inert. Does not decompose when subjected to fire. Does not cause corrosion or damage materials and equipment.
- Vaporizes completely on discharge. No clean-up of agent required.
- Protected facilities can be back in operation with a minimum of delay.
- Suitable for Class A, B and C fires.
  - Four proven and standard methods of application:
    - Total flooding, surface burning.
    - Total flooding, deep seated burning.
    - Local application, area method.
    - Local application, volume method.
- Accommodates long pipe runs.
- Readily accommodates systems with selector valves (integrated systems that protect more than one hazard from a common carbon dioxide supply).
- Carbon dioxide discharges by the force of its own expansion. Does not require super-pressurizing agents, pumps, or other pressurizing mechanisms.
  - May be used simultaneously with other types of extinguishing agents with no effect on extinguishing efficiency.

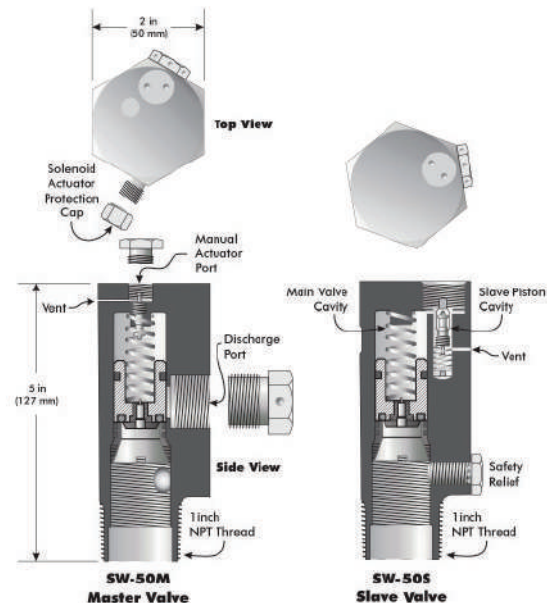

# High Pressure CO<sub>2</sub> extinguishing systems explained

High pressure storage systems are comprised of CO<sub>2</sub> cylinders stored at ambient temperatures. At 70 °F (21 °C), the pressure in this type of storage container is 850 psi (5860 kPa).

Low pressure storage systems, on the other hand, are comprised of CO<sub>2</sub> cylinders stored at a controlled low temperature of 0 °F (-18 °C). At this temperature the pressure in this type of storage is 300 psi (2068 kPa).

## Advantages of high pressure systems

- High pressure cylinders are available in 50, 75 and 100 lb (20, 34 and 45 kg) capacities. Low pressure containers are typically available in one ton increments. This greater flexibility among high pressure systems allows the system designer to allocate storage with greater efficiency, thus saving storage space and money.
- Refrigeration of carbon dioxide is not required. Cylinders can be stored without any special treatment at temperatures between 0 °F and 130 °F (-18 °C and 54 °C) for total flooding systems, and 32 °F to 120 °F (0 °C to 49 °C) for local application.
- Cylinders can be easily adjusted for higher or lower temperatures by underfilling for higher temperatures, or adding nitrogen for lower temperatures.
- Flexible space requirements – if a single large space is not available, multiple cylinder banks can be divided and stored in a number of smaller locations.
- Flexible for weight requirements – if floor loading is a problem, multiple cylinder banks can be divided and stored in a number of locations to distribute the floor loading.
- Electric power is not required for high pressure carbon dioxide storage.

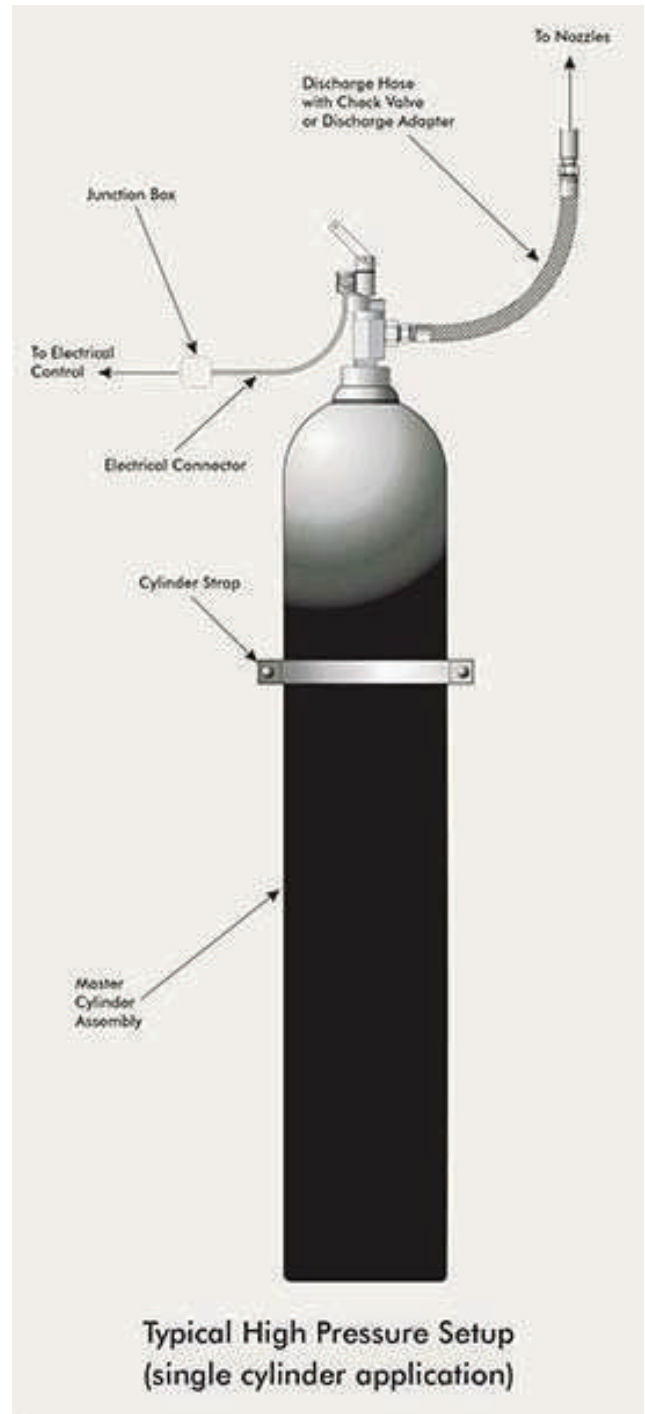

## Principles of Operation

A carbon dioxide system consists of a battery of one or more cylinders, manifolded together and connected to a system of distribution pipework terminating in special carbon dioxide discharge nozzles. These systems are custom designed for the specific application. The quantity of carbon dioxide required for the protection of any particular hazard is dependent on the cubic capacity or the surface area of the hazard, together with the type of material involved, temperature of the hazard, and with allowance for special conditions.

More than one hazard can be protected by the same bank of cylinders, and these systems are referred to as joint systems. Selector or directional valves are utilized to direct the carbon dioxide to the fire area. An interconnected reserve bank of cylinders is generally recommended for this type of protection.

inControl brand carbon dioxide systems may be actuated manually or automatically. Automatic systems incorporate fire detectors and controls. The fire detectors are located in the hazard area, and when a fire occurs, send a signal to the control panel which releases the carbon dioxide. Automatic systems are electrically operated and always incorporate a manual override feature.

## Method of Application

**Total flooding** injects a sufficient volume of carbon dioxide into an enclosure so that an inert atmosphere is created. The enclosure should be reasonably well sealed and doors, vents and other openings should be arranged to close on the discharge of the system. Enclosures with openings that cannot be closed can be protected if known at the design stage. For deep-seated type hazards (insulation, rags, storage vaults, etc.) the enclosure must be well sealed to retain the carbon dioxide for a long period of time. The location and orientation of discharge nozzles for these applications is not of major concern, minor deviations to project design can generally be accommodated.

**Local application** is the method used to protect a specific hazard (engine, dip tank, etc.) within an enclosure – without flooding the entire enclosure. Nozzles are arranged to discharge carbon dioxide directly onto the hazard, to build up an inert atmosphere immediately surrounding the hazard. For this application, the layout of piping and nozzles is critical, and deviations to project design must not be made unless approved by the

## Properties of CO<sub>2</sub> as a Fire Extinguishing Agent

Carbon Dioxide (CO<sub>2</sub>) is a colorless, odorless, clean, dry, electrically non-conducting, non-corrosive, non-damaging and nondeteriorating inert gas, that is approximately 50 percent heavier than air.

Carbon dioxide is a standard commercial product. It is commonly used for carbonating beverages, for fast freezing food, for medical purposes, and for purging pipes and tanks, as well as for extinguishing fires. Carbon dioxide is available in most cities and seaports throughout the world.

When inhaled, CO<sub>2</sub> produces a tingle in the nostrils, the same as is experienced when drinking carbonated beverages. Carbon Dioxide stimulates breathing (increases the rate of breathing), and is useful in small controlled doses in the resuscitation of drowning and electric shock victims.

Carbon Dioxide is stored in liquid form in high pressure steel containers, usually at 850 psig at 70 °F (58 bar at 21 °C). It may also be stored at 300 psig at 0 °F (20 bar at -18 °C), for special large requirements. One of carbon dioxide's most valuable properties is its amazing high ratio of expansion, approximately 450 to 1. Carbon dioxide is discharged from the cylinder by the force of its own expansion – without the need for pumps or other pressurizing mechanisms. Carbon dioxide will penetrate every nook and corner of a space where fire might lurk.

On discharge, carbon dioxide creates a cold fog. The temperature of carbon dioxide discharging from a nozzle is approximately 110 °F below zero. This cloud effect, or fogging, is due to the moisture in the air being frozen by the extremely low temperature of the Carbon Dioxide and fine “snow” accompanying the discharge. The fogging will generally dissipate after a few minutes.

## How Carbon Dioxide Extinguishes Fire

Carbon Dioxide extinguishes fire by diluting the oxygen content of the space to a point where it will not support combustion. Reducing the oxygen content from the normal 21 per cent in air to 15 per cent will extinguish most fires. For some materials the oxygen content must be reduced below 15 per cent, and in some cases its concentration needs to go down to as low as six percent of the volume. Surface and flash type fires (oils, paints, etc.,) are quickly extinguished, while smouldering or deep-seated fires (baled cotton, clothing, etc.) are extinguished by the prolonged action of a high concentration.

In addition to its smothering action, the reduction in temperature due to its rapid expansion will provide some suppression caused by the cooling effect.

# Carbon Dioxide Fire Protection Systems

## Cleanup following a CO<sub>2</sub> discharge

Carbon Dioxide vaporizes completely on discharge. Whereas the cost of clean-up and peripheral damage associated with water, foam, and dry chemical agents can exceed the cost of the fire damage itself, cleanup costs associated with carbon dioxide are negligible.

Carbon Dioxide is inert and most materials and equipment are totally unaffected by exposure to it. Carbon dioxide is stable, even at high temperatures, and does not decompose when subjected to fire, therefore it does not cause metals to corrode.

The reduction in temperature, caused by the dramatic expansion of the Carbon Dioxide as it discharges from the nozzles, can have a strong chilling effect on objects, including cord shock to delicate electrical equipment.

## Compatibility with other Extinguishing Agents

Carbon Dioxide may be used simultaneously with other types of fire

extinguishing agents for fire fighting purposes. There are no known indications that extinguishing efficiency will be affected.

## Use and Limitations

Carbon Dioxide Systems may be utilized for Class, A, Band C fires (North American definition). They are particularly useful for extinguishing fires in specific hazard areas or equipment:

- a) where an inert, electrically non-conductive medium is desirable,
- b) in high value occupancies particularly susceptible to fire, smoke, and water damage.
- c) where clean up of another medium would present a problem,
- d) where they are as efficient as, but more economical to install than systems using other extinguishing agents.

Carbon dioxide will not extinguish fires involving the following materials:

- a) chemicals containing their own oxygen supply such as cellulose nitrate,
- b) reactive metals such as sodium, potassium, magnesium, titanium, zirconium, uranium and plutonium,
- c) metal hydrides.

While carbon dioxide will not extinguish these fires, it will not react dangerously with these materials or increase their burning rate. Carbon Dioxide, if used in this type of situation in a total flooding system, will provide protection for adjacent combustibles. Local application systems with attendant high velocity directed discharge should not be used.

Caution is required where carbon dioxide may be discharged into potentially explosive atmospheres. Electrostatic charging of non-grounded conductors may occur during the discharge of liquefied gases. These conductors may discharge to other objects, causing an electric spark of sufficient energy to initiate an explosion.

---

## CO<sub>2</sub> Safety Precautions

Safeguards must be taken to ensure the safety of personnel in areas where the atmosphere could be made hazardous by the discharge of carbon dioxide. The following list, which is strongly recommended, is generally taken from NFPA 12: Standard on Carbon Dioxide Extinguishing Systems.

- a) Provide adequate aiseways and routes of exit and keep them clear at all times.
- b) Provide emergency lighting and directional signs as necessary to ensure quick, safe evacuation.
- c) Provide alarms within such areas that will operate immediately upon detection of the fire, with the discharge of the carbon dioxide and the activation of automatic door closures delayed for sufficient time to allow evacuation of the area before discharge begins.
- d) Provide only outward swinging self-closing doors at exits from hazard areas, and, where such doors are latched, provide

panic hardware.

e) Provide continuous alarms at entrances to such areas until the atmosphere has been restored to normal.

f) Provide warning and instruction signs at entrances to and inside such areas. These signs should inform persons in, or entering the protected area that a carbon dioxide system is installed, and may contain additional instructions pertinent to the conditions of the hazard.

g) Provide for the prompt discovery and rescue of persons rendered unconscious in such areas. This may be accomplished by having such areas searched immediately by trained persons equipped with proper breathing equipment. Self-contained breathing equipment (and personnel trained in its use, and in rescue practices, including artificial respiration), should be readily available.

h) Provide instruction and drills for all personnel within or in the vicinity of

such areas including maintenance or construction people who may be brought into the area), to ensure their correct action when carbon dioxide protective equipment operates.

i) Provide the means for prompt ventilation of such areas. Forced ventilation will often be necessary. Care should be taken to really dissipate hazardous atmospheres and not merely move them to another location.

j) Carbon dioxide is much heavier than air and can collect in pits, cellars and low-lying areas. Care should be taken when entering such areas after carbon dioxide has been discharged.

k) Provide means to lock off or disarm the system during periods of system inspection, maintenance, or modification.

l) Provide such other steps and safeguards that a careful study of each particular situation indicates are necessary to prevent injury or death.

# Standard equipment and optional components

## Cylinder Assemblies

A basic cylinder assembly consists of a pressure vessel, a valve and siphon tube assembly, and a charge of carbon dioxide.

A variety of cylinder sizes are available. They are all designed to hold pressurized carbon dioxide in liquid form at atmospheric temperatures, corresponding to a nominal pressure of 850 psi at 70 °F (58.6 bar at 21 °C).

All cylinders are seamless. They are manufactured and tested in accordance with the requirements of Transport Canada and/or Department of Transport (USA), Specification 3AA-1800 or higher. Large cylinders having capacities of 35, 50, 75 and 100 pounds (15.9, 22.7, 34 and 45 kg) are made of steel. Small cylinders, used for special applications, have capacities of 10 and 15 pounds (4.5 and 6.8 kg) and may be made of aluminum or steel, depending on availability.

Except for special temperature conditions, all cylinders are filled to their specified weight with liquid carbon dioxide. Cylinders are not partially filled.

The pressure inside the cylinder will vary as the temperature changes. In general, the ambient storage temperature for standard cylinders used in local application systems should be between 32 °F and 120 °F (0 °C and 49 °C). For standard cylinders used in total flooding systems, the ambient storage temperature should be between 0 °F and 130 °F (-18 °C and 54 °C).

Two cylinder valves are available: the SW-50M (master) and the SW-50S (slave). Both are manufactured of brass with an optional nickel plated finish. The valves are of the force differential type using a piston seal. The pressure above the piston is maintained at cylinder pressure, but the area at the top of the piston is

greater than the seal area. This results in a higher force above the piston, which acts to keep the valve closed.

To open the valve, the pressure above the piston is vented and cylinder pressure raises the piston to open the valve. A transport plug is attached to the valve by a chain and must be attached to the discharge port when the cylinder is disconnected from the discharge piping.

A pressure relief safety disc, incorporated into the cylinder valve, is designed to release pressure should the cylinder be subjected to exceptionally high temperatures or other abnormal conditions. The disc rupture point is in the range of 2,600 to 3,000 psi (182.7 to 206.8 bar). The safety disc nut is of a type that will relieve pressure without cylinder recoil.

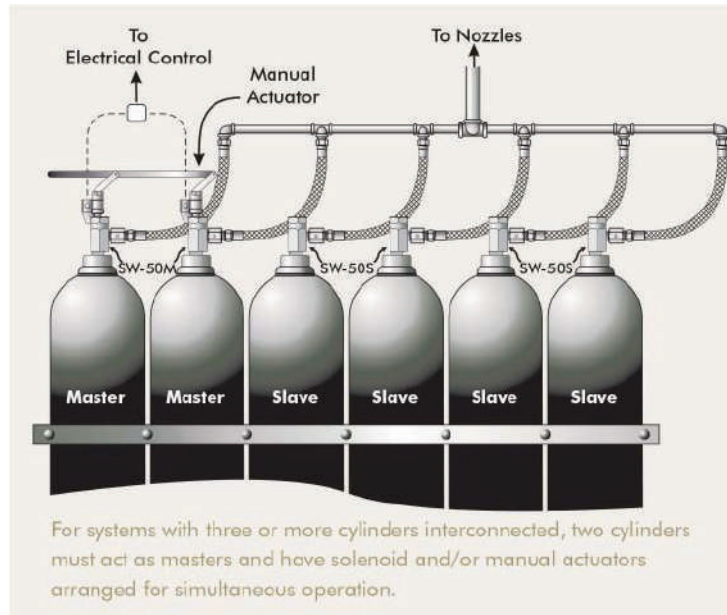

The SW-50M master valve can be operated manually, by pressure actuator, with a solenoid valve kit, or by direct back pressure from the discharge manifold. The SW-50S slave valve can be operated only by direct back pressure from the discharge manifold.

Single cylinder systems simply require a single SW-50M with a manual actuator and/or a solenoid valve. This is generally referred to as a master cylinder. For systems with two cylinders interconnected, only one master valve is required. The other

cylinder is operated by a SW-50S slave valve. For systems with three or more cylinders interconnected, two cylinders must act as masters and have solenoid and/or manual actuators arranged for simultaneous operation.

A rigid siphon tube is used in all cylinders to ensure liquid discharge. All cylinders must therefore be installed in the normal upright position.

# Carbon Dioxide Fire Protection Systems

## Discharge Bends

and Discharge Adapters A discharge bend is used to connect the cylinder valve outlet to the system manifold and discharge piping. This flexible hose allows for the temporary misalignment of the cylinders on installation, and for ease of cylinder removal for maintenance. The cylinder end of the hose has a swivel connection for ease of installation.

A discharge bend with a built-in check valve must be used when cylinders are manifolded together. The check valve is locked onto the hose assembly and must not be separated from it. If a cylinder assembly is disconnected from the discharge bend, and if the system operates while the cylinder is disconnected, the check valve will ensure that an appreciable quantity of carbon dioxide will not discharge from the disconnected discharge bend.

Flexible discharge bend adapter combinations are available for single cylinder systems where a check valve is not required. When the discharge adapter is used without the flexible bend, a union connection must be installed close to the cylinder for ease of installation and maintenance.

It is important that neither the discharge bends nor the discharge adapter be mounted onto the cylinder valve during transportation and storage. The transit plug must remain in place on the cylinder valve until the cylinder is installed and secured in its bracket.

## Cylinder Brackets

The cylinders can be arranged to be bracketed to a wall or to be free standing when no wall is available. Straps for single cylinder wall mounting installations are available from your inControl Systems dealer. Brackets for multiple wall mounted installations and frames for multiple cylinder free standing installations are normally supplied by the installer, and assembled on site to suit the space available.

For installation of three or more cylinders, a variety of arrangements can be fabricated by the installer.

The single row, wall mounting arrangement is recommended for installations of up to five cylinders.

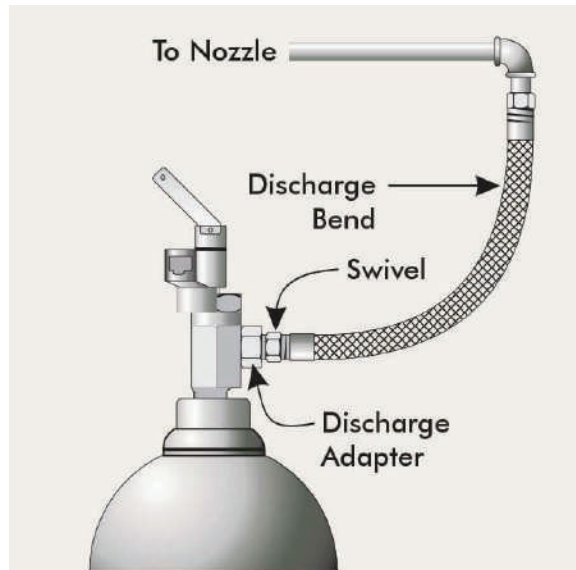

Typical single cylinder discharge bend

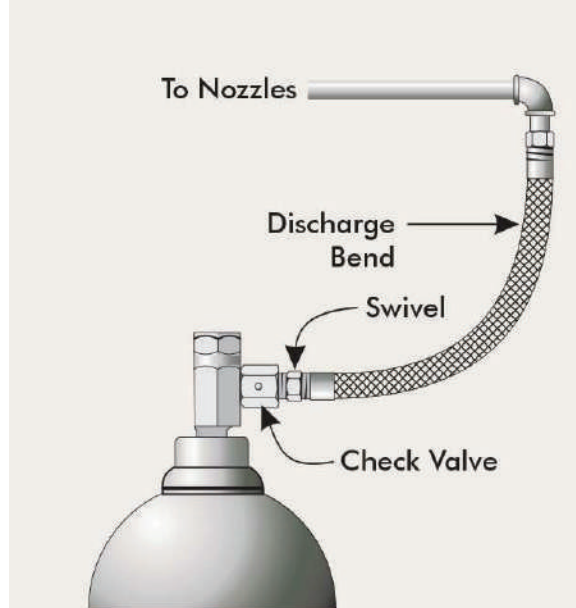

Typical manifold discharge bend (slave)

Double row, free standing arrangements have the advantage (particularly for systems using main and reserve cylinders, and for joint systems), that any cylinder can be removed for recharging without disturbing the others. However, this arrangement requires two aisles and considerably more space.

The double row, wall mounting arrangement is generally used when sufficient space is not available for a free standing arrangement or for a single row wall mounting arrangement.

For marine applications, additional cylinder supports are required. Two straps or sets of retainers must be used.

## Check Valves

A range of check valves are available. These are used to isolate the main cylinder manifold from the interconnected reserve cylinder manifold. In the manifolds of joint systems they are also used to prevent the discharge from activated cylinders causing activation of the other cylinders in the bank.

## Bleeder Valves

Bleeder valves are used in the manifolds of main and reserve banks of cylinders, as well as in the manifolds of systems that have selector valves (joint systems). The bleeder valve vents accidental check valve leakage (that could discharge the other bank or banks of cylinders) from one bank to the other. The valve is normally open and closes when manifold pressure reaches approximately 20 psi (1.4 bar)

to prevent loss of CO<sub>2</sub> under normal discharge conditions. The pipe connection is 1/2" NPT.

## Discharge Nozzles

Two types of discharge nozzle are available: total flooding type and local application type. Total flooding nozzles are used where an even distribution of gas is required throughout an enclosure. Local application or directional nozzles are used where a concentration of carbon dioxide is required on a particular surface or piece of equipment.

Nozzles are designed to discharge large volumes of carbon dioxide without freezing. For local application use (when installed in accordance with their approvals), the velocity of discharge from the nozzle is reduced to prevent agitation and splatter of the hazardous material which could spread the fire.

All nozzles have a drilled orifice. The nozzle orifice size will vary depending on the flow and the location of the nozzle in the system. It is important that nozzles are installed exactly as specified on the project drawings, otherwise system performance will be jeopardized.

The wall type and vent type nozzles are used exclusively for total flooding installations. The S-Type nozzle may also be used for total flooding installations, however, its cost normally restricts its use to local application installations. The S-Type nozzle may be fitted with flanges to enable it to be mounted onto sheet metal equipment enclosures and ductwork. It may also be supplied with a frangible disc to prevent clogging of the orifice. Special finishes for nozzles are available and can be provided by special order to suit project requirements.

## Manual Control

A manual actuator is used to operate the carbon dioxide system manually and locally at the cylinders. The actuator is screwed into a port on the top of the SW-50M cylinder valve. When two master cylinders are required, the levers of the two actuators are joined together with a connecting link for simultaneous operation.

The actuator has a hole in the side of the main body fitted with a blank plug. This hole allows the actuator to be operated from an external pressure source. It is also used to connect to the discharge from the solenoid valve (when used). The blank plug is removed from the actuator only for these two purposes. Otherwise the plug must remain tightly connected at all times.



The hand lever on the manual actuator can be operated from a remote location. This is achieved by connecting a 1/16-inch diameter stainless steel cable to the end of the lever, and running the cable through 1/2-inch conduit or 3/8-inch pipe to a pull box using corner pulleys at each change in cable direction.

Using a mechanical dual junction box, two remote pull boxes can be joined to operate one master cylinder arrangement. Or, one remote pull box can be used to operate two separate manual actuators.

## Automatic Control

Electric actuation is achieved by using a solenoid valve kit. The solenoid valve is a normally closed device, closed when de-energized and open when energized. The standard solenoid voltage is 24 VDC, but other voltages and special enclosures (including explosion-proof) are available by special order. The standard electric connection is by a DIN connector, and a cable assembly is available for ease of connection to field wiring.

The solenoid coil is designed and rated for continuous duty service. However, it is recommended that the actuating circuit incorporate a shut-down device (e.g. a pressure switch or time delay relay) to open the circuit when the cylinder is empty.

When the coil is energized for a long period of time, the solenoid enclosure becomes hot. This is a safe operating temperature and will not damage the solenoid. Any excessive heating will be indicated by the smoke of burning coil insulation.

The solenoid valve connects directly to a special adapter on the SW-50M cylinder valve. The discharge side of the solenoid valve is connected to the pressure port on the manual actuator with supplied 3/16-inch braided hose. When de-energised, the solenoid valve opens allowing pressure from above the main piston of the cylinder valve to operate the actuator and open the valve.

The solenoid should be connected to a Listed control panel that is powered through a separately used circuit, and that also incorporates battery backup power.

# Carbon Dioxide Fire Protection Systems

## Control Panels

Any control panel specifically listed for extinguishment control (releasing panel) that provides continuous supervision, and that is compatible for the interconnection of all devices, may be used. Listed control panels provide fully supervised detection, signalling and activation control – as well as audible and visual annunciation of the system status. They also provide battery backup power, and control of auxiliary equipment.

## Initiating Devices

Initiating devices such as heat detectors, smoke detectors, and manual stations should be listed devices compatible with the control panel being utilized. See the respective manufacturers instruction manuals for installation and operating details. A remote electric manual station should be included in all automatic electric systems. This allows the system to be manually actuated should a fire be visually detected before an automatic detector operates.

## Pressure Operated Switch

The pressure operated switch connects to the carbon dioxide discharge piping and operates when the system discharges. The switch may be wired with contacts in the open or closed position. Operation causes the electrical switch contacts to reverse position. Switches can be used to confirm system discharge, to operate alarms, to shutdown motors, pumps, fans and conveyors, to release magnetic door holders, etc., automatically when the system discharges. The switch may be mounted in any position, but preferred installation is with the pressure connection (CO<sub>2</sub> supply line) entering from the bottom. The switch enclosure is rated for standard and weatherproof conditions. When the line load of the equipment to be operated is greater than the switch rating, the switch should be used to break a relay holding-coil circuit.

## Pressure Release Trip

The pressure release trip can be used to release dampers, close fire doors, windows, louvres, fuel supply valves, to open dump valves, etc., automatically when the system discharges. The equipment to be operated must be weight or spring loaded, or be pivoted off centre. The release trip is connected to the carbon dioxide discharge piping for operation when the system discharges. Cable from the equipment to be controlled is looped over the pressure release operating stem. When the trip is operated, the stem retracts and the cable is released.

## Changeover Switch

The change-over switch is a rotary type used to direct automatic actuation to a main or reserve cylinder bank when main and reserve cylinders are provided. The switch should be located adjacent to the cylinder bank or in a secure area.



## Header Safety

This pressure relief device is installed in sections of closed piping such as between selector valves and the cylinder manifold. It is a frangible disc assembly designed to rupture if trapped CO<sub>2</sub> expands and the line pressure exceeds 2,650 to 3,000 psi (182.7 to 206.8 bar). The body is made of brass and the pipe connection is ½" NPT.

## Gas Operated Siren

This unit sounds an alarm by means of carbon dioxide pressure. It is connected to the discharge piping of the system, or to a separate independent carbon dioxide cylinder. Sirens should be located throughout the hazard area in order to ensure an audible alarm will be heard on the activation and discharge of the carbon dioxide system. Due consideration should be given to the normal background noise in the area.

If the carbon dioxide system incorporates a delayed action device, the siren must be arranged to operate at the same time that the delayed action device is initiated. When connected to the carbon dioxide system piping, the alarm will cease when the gas discharge has been completed. If it is desirable or necessary for the sirens to operate for a longer period of time than will be allowed by the system discharge time, a separate independent carbon dioxide cylinder must be used.

# Applications

Time delay installation, multiple cylinders, with gas operated sirens

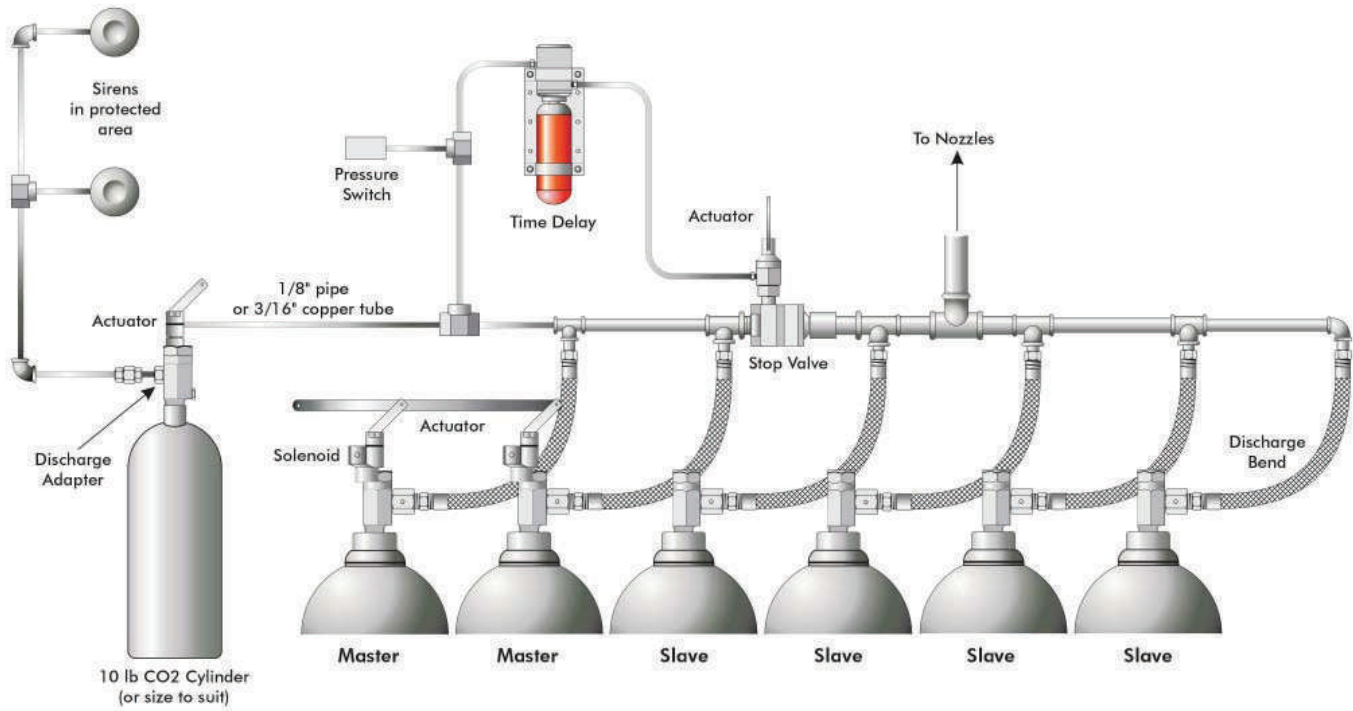

## Main and reserve cylinders

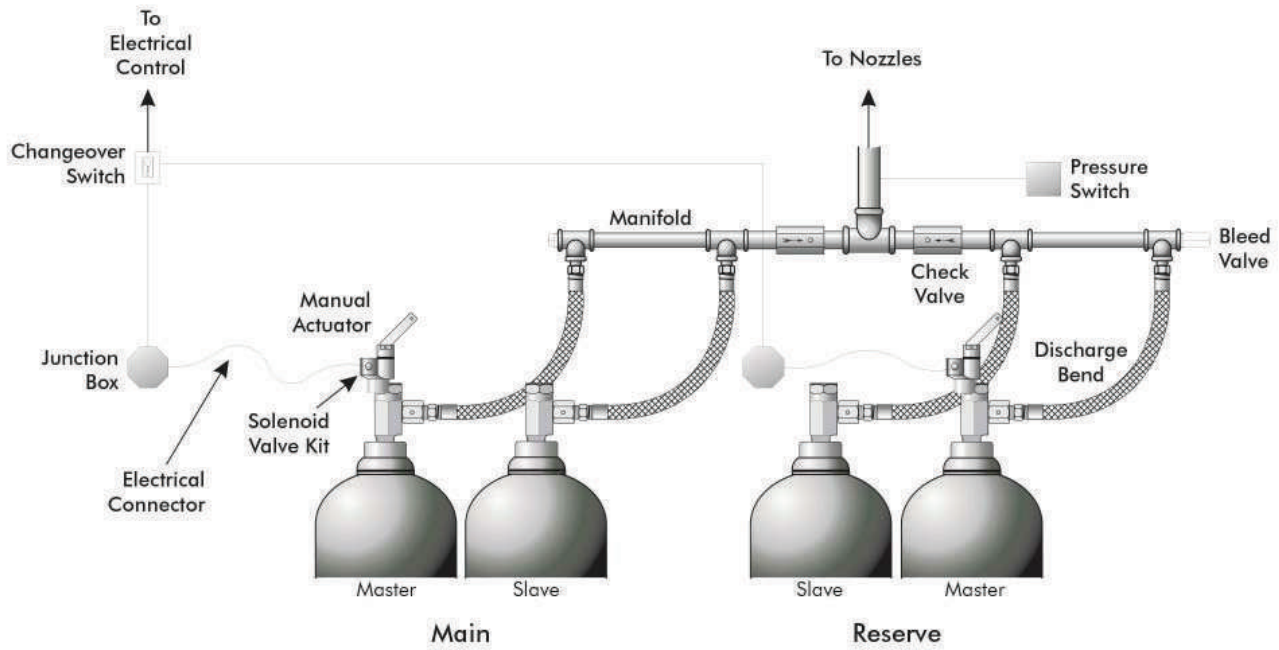

# Carbon Dioxide Fire Protection Systems

## Bracket Installation

Single bank, wall mounting is recommended for installations of up to five cylinders. Freestanding arrangements allow for multiple banks while maintaining sufficient access to all cylinders for maintenance or replacement purposes.

Top View

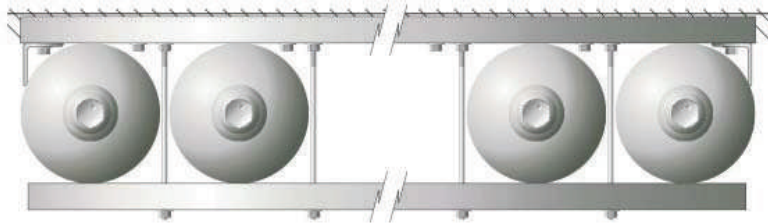

Typical Bracketing Layout  
Single Bank, 100 lb Cylinders

Top View

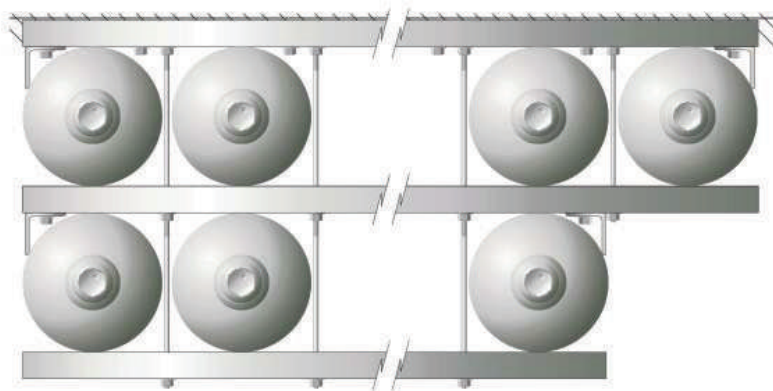

Typical Bracketing Layout  
Double Bank, 100 lb Cylinders

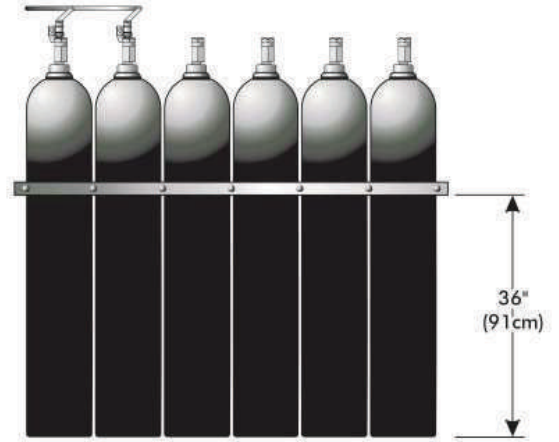

Single Bracket  
Standard Industrial Installations

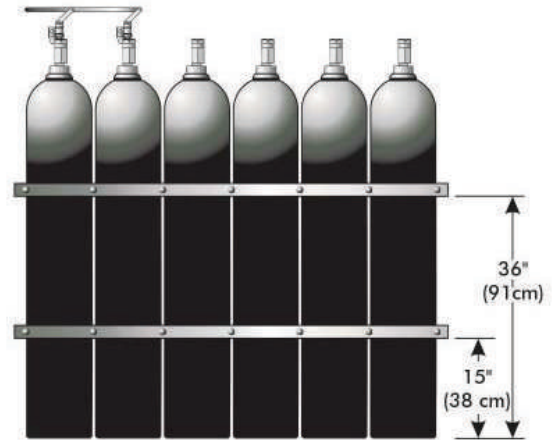

Double Bracket  
Marine Installations

## Strap Installation

For floor mounted cylinders against a solid wall. Mounting bolts must be anchored to a solid structural member.

Top View

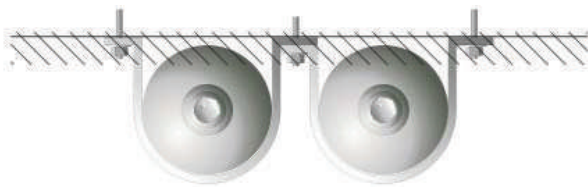

Two Cylinder  
Installation

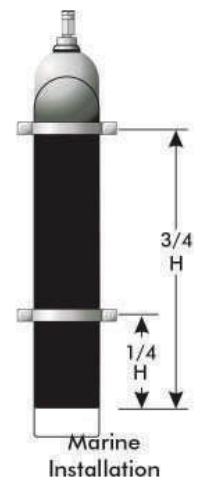
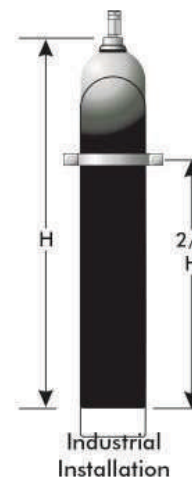
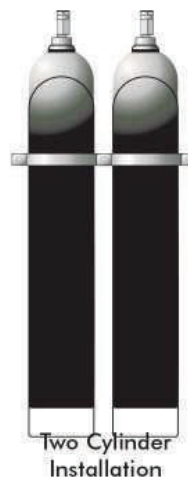

**Cylinder Assemblies**

Carbon dioxide cylinders may be located inside or outside the protected space, although it is preferable to locate them outside the space. When they are installed within the space they protect, a remote manual control should be installed to ensure the system can be actuated from a safe location outside the fire area.

The cylinders should be located to provide convenient access so that they can be readily inspected and easily removed after use for recharging. They should not be installed where they will be exposed to the weather elements or the direct rays of the sun. Cylinders should not be installed where they will be subjected to

temperatures of less than 0 °F (-18 °C) or higher than 130 °F (54 °C), unless otherwise specified.

If cylinders are located in a hazardous (explosion-proof) area, the cylinder solenoid control and all other components

should be approved for such use, and the installation of all materials needs to be done in an approved manner.

Cylinders should be installed in the normal upright position. All cylinders are provided with a siphon tube.

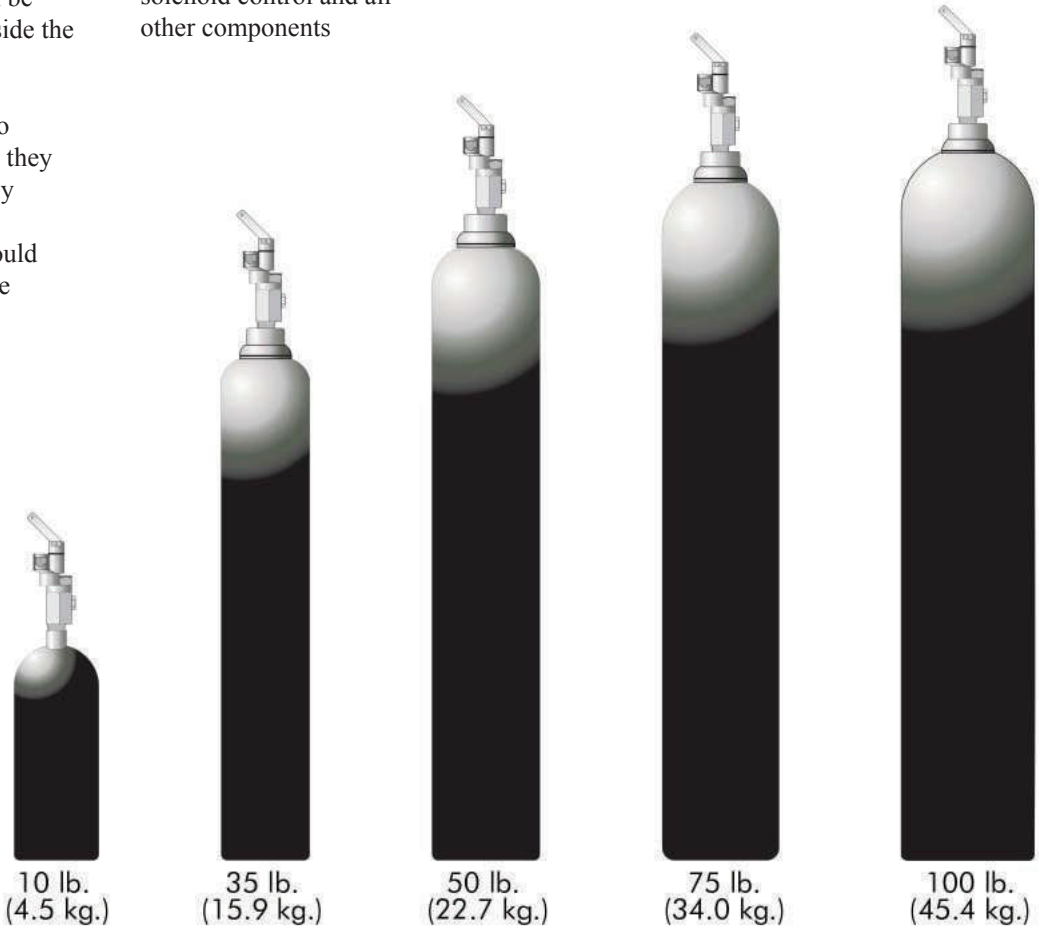

**Dimensions**

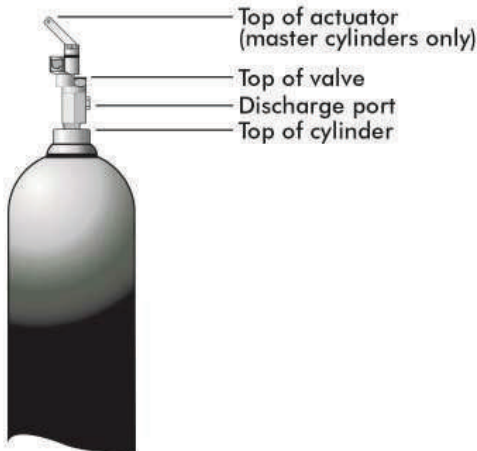

	Width of cylinder	Height of cylinder	Height to discharge port	Height to top of valve	Height to top of actuator
10 lb. (4.5 kg.)	6.73" (17.1 cm)	18" (45.7 cm)	20.35" (51.7 cm)	22.6" (57.4 cm)	27.6" (70.1 cm)
35 lb. (15.9 kg.)	8.63" (21.9 cm)	35" (88.9 cm)	37.35" (94.9 cm)	39.6" (100.6 cm)	44.6" (113.3 cm)
50 lb. (22.7 kg.)	8.50" (21.6 cm)	51" (129.5 cm)	53.35" (135.5 cm)	55.6" (141.2 cm)	60.6" (154.0 cm)
75 lb. (34.0 kg.)	9.25" (23.5 cm)	56" (142.2 cm)	58.35" (148.2 cm)	60.6" (154.0 cm)	65.6" (166.6 cm)
100 lb. (45.4 kg.)	10.56" (26.8 cm)	58" (147.3 cm)	60.35" (153.3 cm)	62.6" (159 cm)	67.6" (171.7 cm)

# SW-50 Cylinder Valve

06-0233	SW-50M Master Valve, Brass
06-0286	SW-50M Master Valve, Nickel Plated
06-0232	SW-50S Slave Valve, Brass
06-0285	SW-50S Slave Valve, Nickel Plated

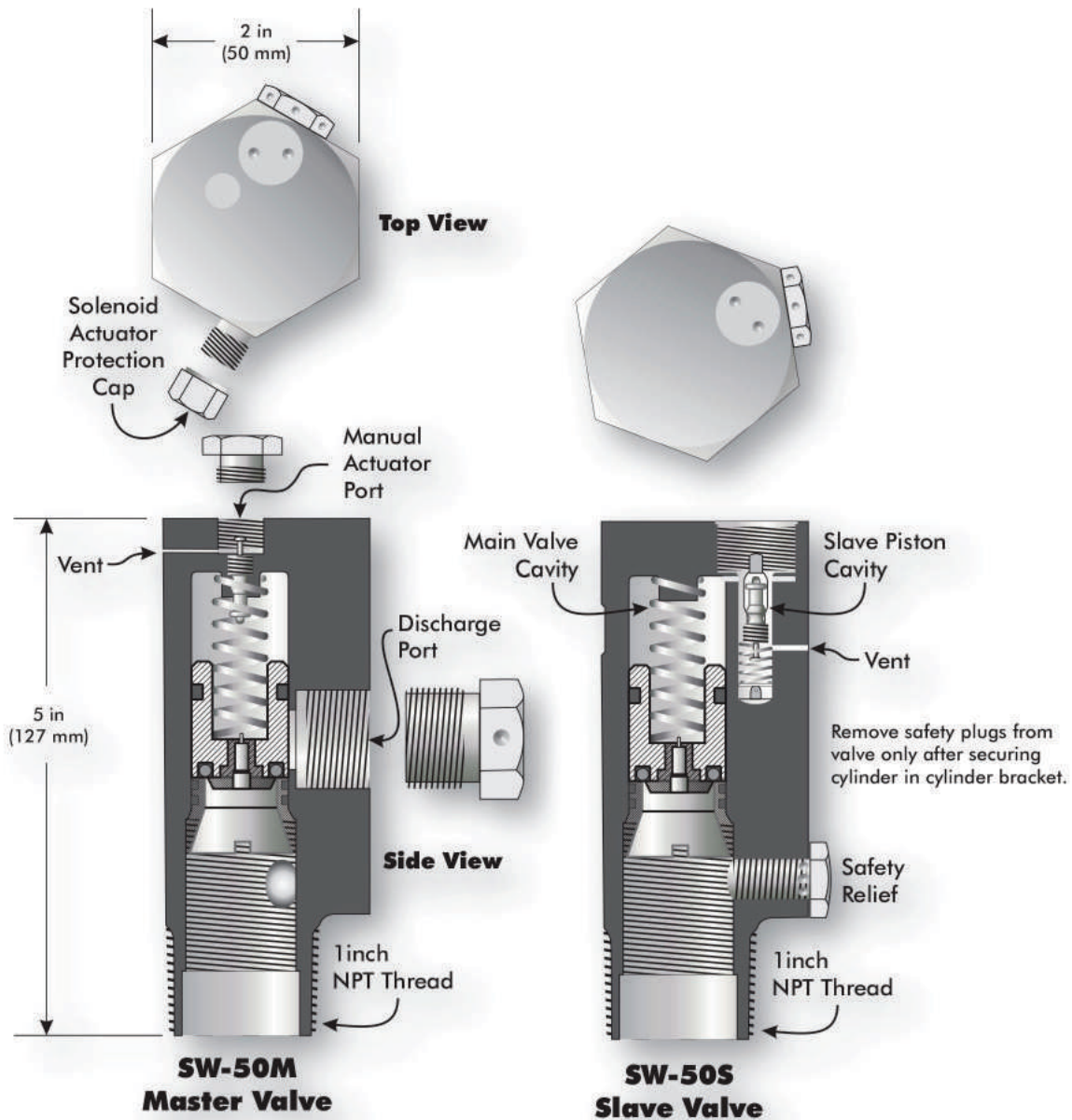

Minimum Burst Pressure	6,000 PSI (414 Bar)
Safety Relief Operating Pressure	2,650 to 3,000 PSI (182 to 207 Bar)
Equivalent Length	5 feet (1.5 m) of 12" Schedule 40 Black Pipe
Dimensions	5" (127 mm) high x 2" (50 mm) wide
Operating Temperature	0 to 130 ( 18 to 54 )
Weight	3.5 lb. (1.6 kg)

# High Pressure C02 Fire Protection Manual/Pressure Actuator

**P/N 06-0235**

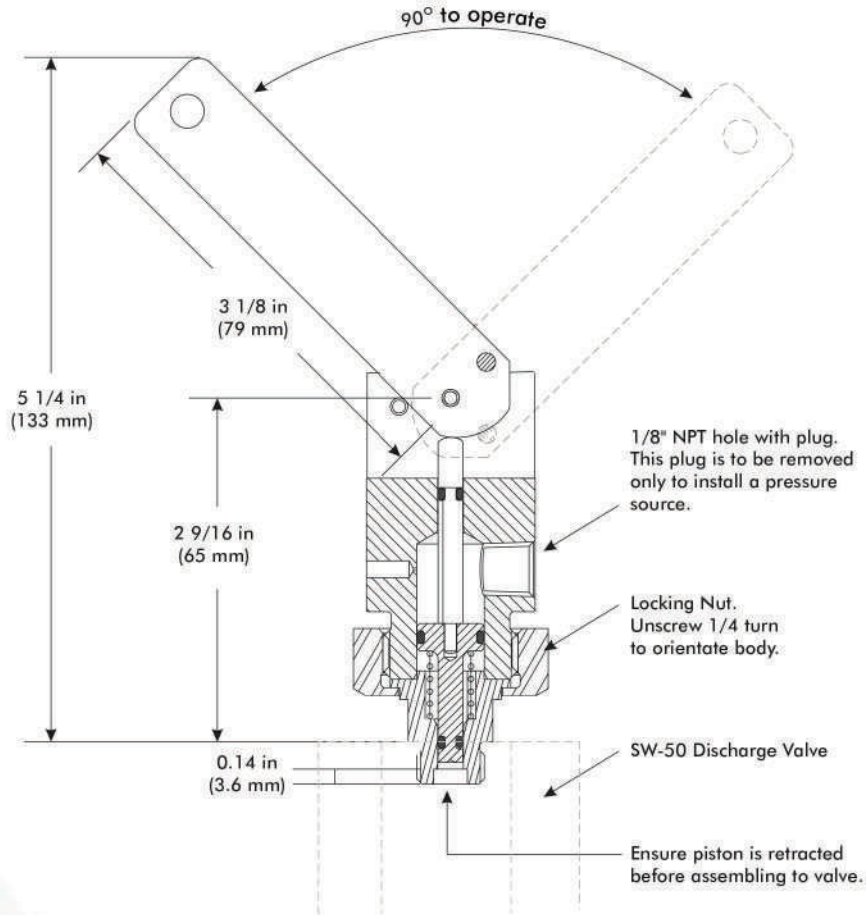

Connecting Link Assembly  
Brass  
04-0099

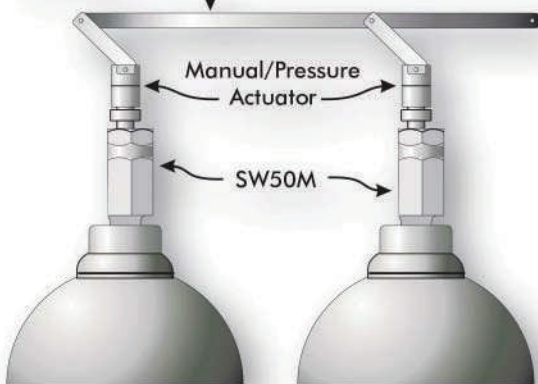

Connecting link used for simultaneous operation of two cylinder valves. Also used for remote manual cable operation, non-tension type.

1. Install actuator only after cylinders have been secured in their brackets.
2. Before connecting actuator to cylinder valve, ensure:
  - a) (a) The pull pin is installed and secured with a seal.
  - b) (b) The piston is retracted as indicated.
3. Install the actuator to the cylinder valve, hand tighten.
4. Minimum pressure required for pressure operation:
  - For 850 psi cylinder pressure (70°): 260 psi
  - For 2,280 psi cylinder pressure (130°): 665 psi
5. when a solenoid actuator is used, discharge from solenoid valve must be connected to the pressure port of the manual actuator.

# High Pressure C02 Fire Protection In-line Check Valves

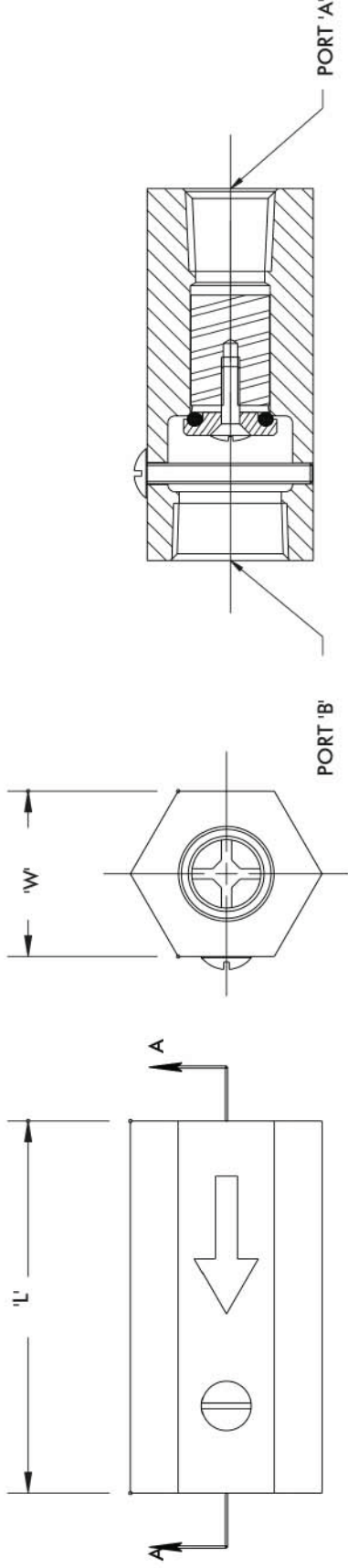

SECTION A-A

Nominal Size (inches)	Port A (IN) NPT	Port B (OUT) NPT	Length L (inches)	Dimension w (inches) A/F	Part No.
1/2	1/2	3/4	3.38	1.50	06-0140
3/4	3/4	1	3.40	1.63	06-0328
1	1	1 1/4	3.75	2.0	06-0327
1 1/4	1 1/4	1 1/2	4.13	2.5	06-0326
1 1/2	1 1/2	2	4.55	3.0	06-0635
2	2	2 1/2	5.82	3.63	06-0636
3	3	3 1/2	7.89	5.26	06-0637

# High Pressure CO<sub>2</sub> Fire Protection Solenoid Actuator

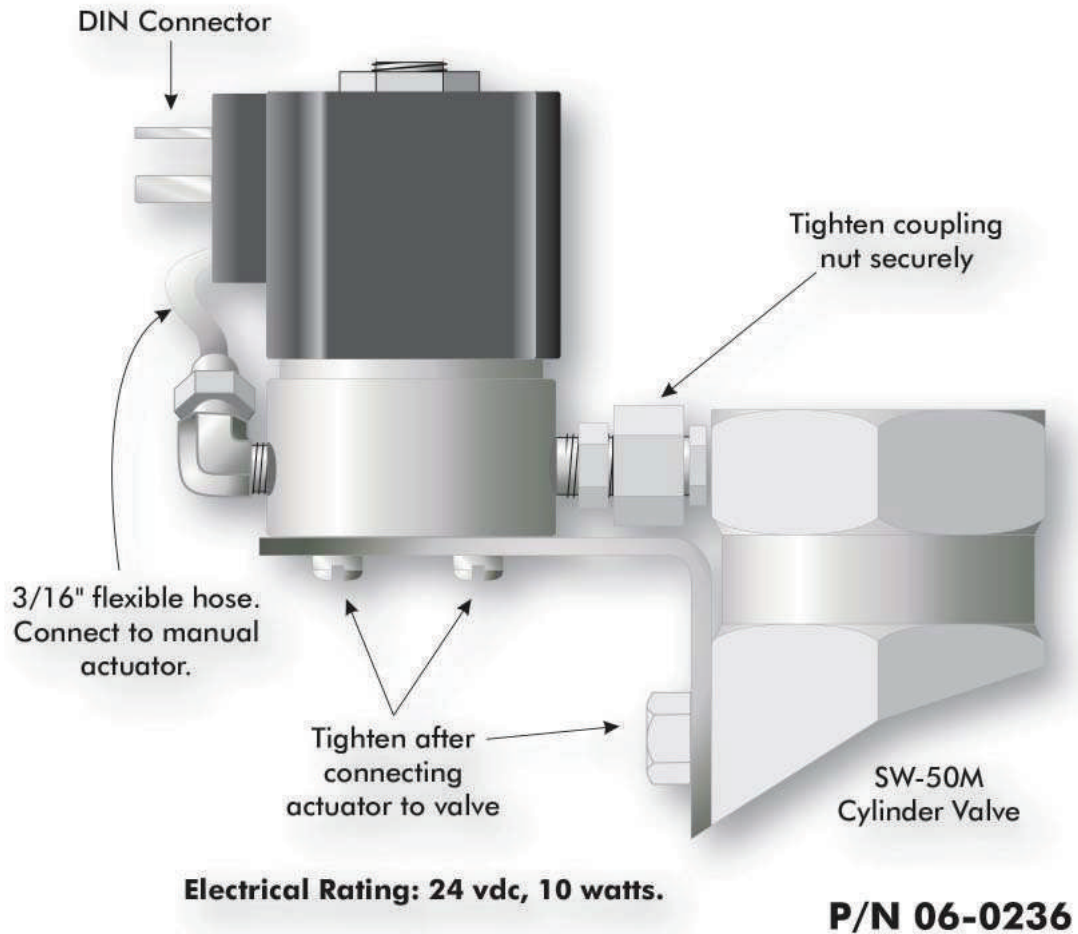

## Important

1. The carbon dioxide cylinder assembly must be restrained in its bracket and discharge piping connected before solenoid actuator is connected to or disconnected from the cylinder valve.
2. The discharge from the solenoid valve must be connected to the manual actuator with the 3/16 inch flexible hose provided.

## Notes

1. The solenoid valve is normally closed. It opens when energized.
2. Solenoid enclosure is a general purpose type. Drip proof, raintight and explosion-proof enclosures are available by special order.
3. Standard voltage is 24 vdc. Other voltages are available by special order.
4. The solenoid valve is designed and rated for continuous duty service.
5. Operating temperature: 0 to 130 °F (-18 to 54 °C).

## High Pressure CO2 Fire Protection

# Explosion Proof Solenoid Actuator

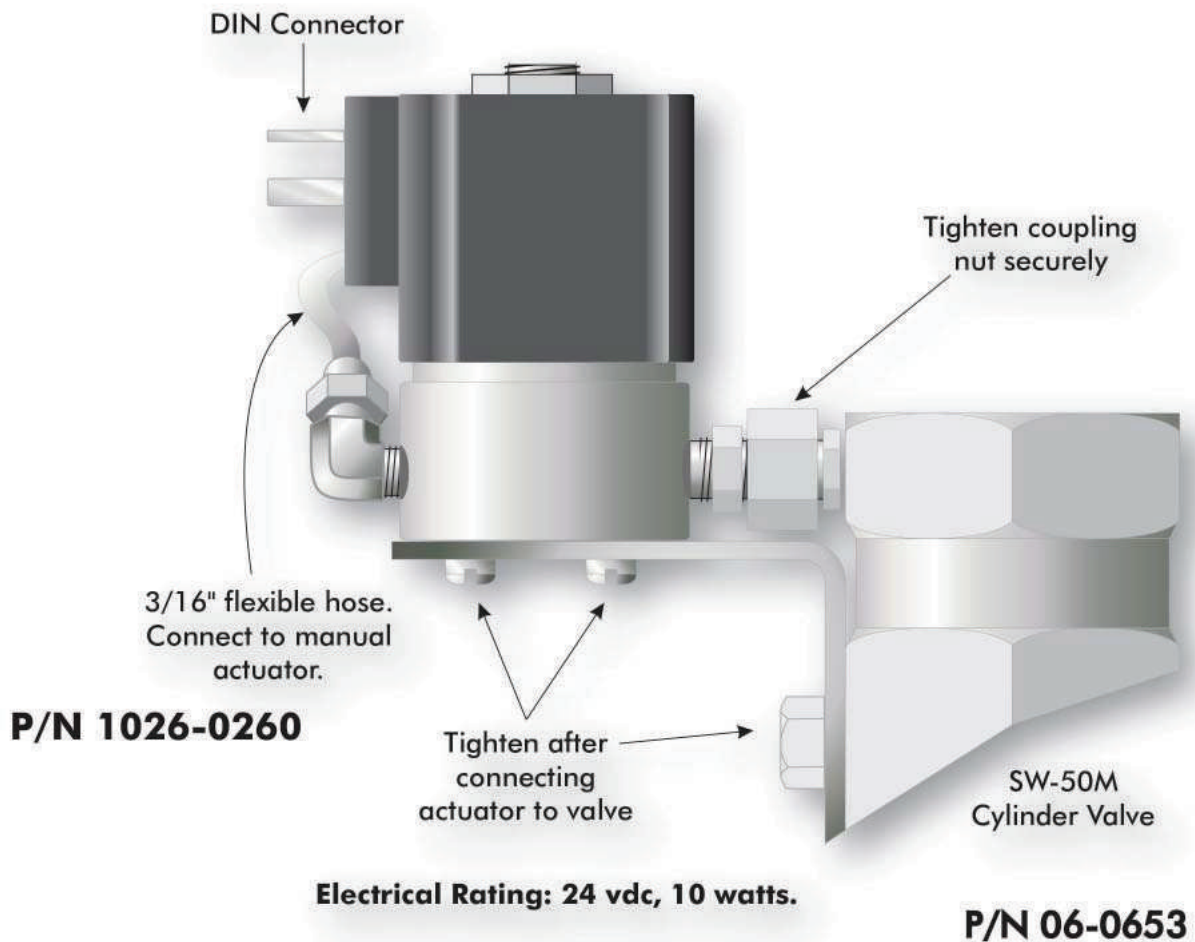

### Standard Features

Body: Stainless Steel (Std.) or Brass (Opt.)

Internal Components: Stainless Steel

Housing: Flame-Proof construction with 1/2" NPT conduit

Hazard Classification: Class I, Div 1, Group C and D  
Class I, Div 2, Group A and B  
Class II, Div 1, Group E, F, and G

Volts: 24 VDC

Watts: 9.5 W

Pressure: 3000 PSI

# High Pressure C02 Fire Protection

## Flexible Discharge Bends

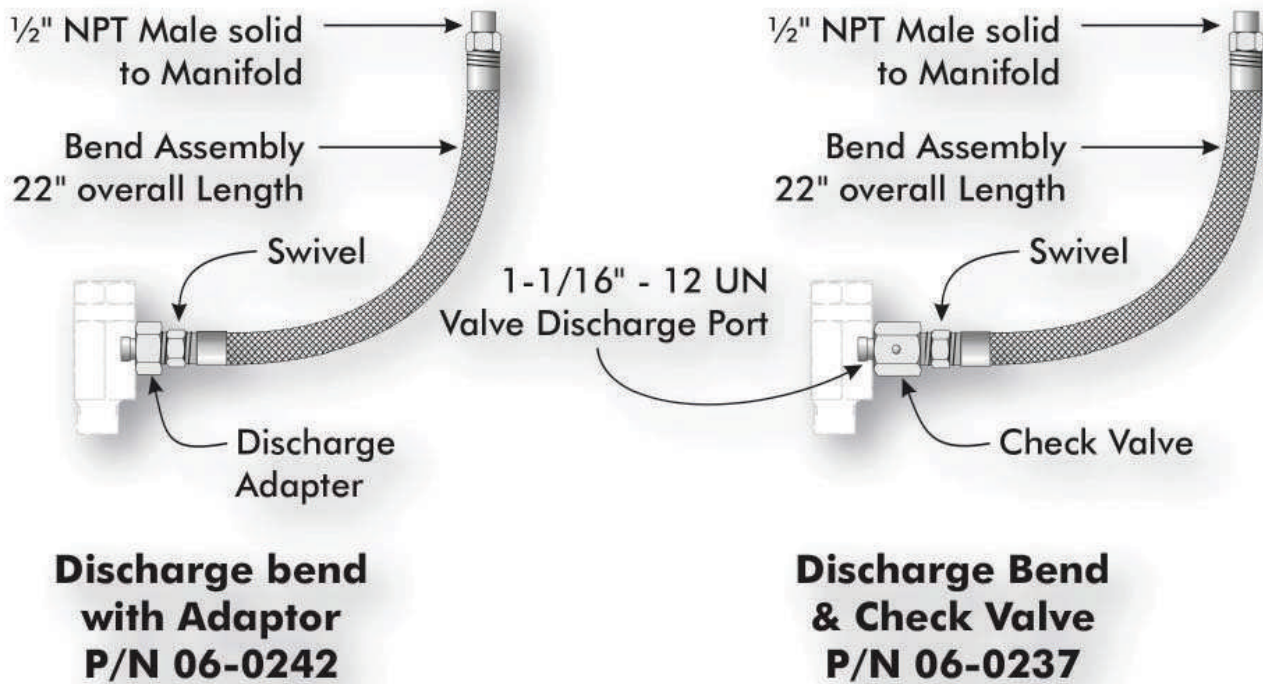

### Use

- The discharge bend and check valve are supplied locked together as a single unit.
- The discharge bend and check valve assembly must be used whenever cylinders are manifolded together.
- The discharge bend and adaptor assembly may be used for single cylinder systems.

### Installation

- Cylinders and manifold must be installed securely before the discharge bends are installed.
- Apply Teflon tape (pipe sealant) to the solid male 1/2" NPT pipe thread on then end of the hose.
- Screw the solid male 1/2" NPT end of the discharge bend into the manifold, wrench tight.
- Remove the safety shipping plug from the discharge port of the SW-50 cylinder valve and install the swivel end of the discharge bend assembly into the discharge port of the valve, wrench tight.

### Hose Specification

Hose Type	SAE I00RI Type AT
Minimum Burst Pressure	5,000
PSI Minimum Bend Radius	9.5 Inches
Equivalent Length, Discharge Bend and Check Valve	7.3 Feet (2.22 m) Of 1/2" Std Black Pipe.

High Pressure CO<sub>2</sub> Fire Protection

**Half inch Wall Nozzle** for Total Flooding Applications

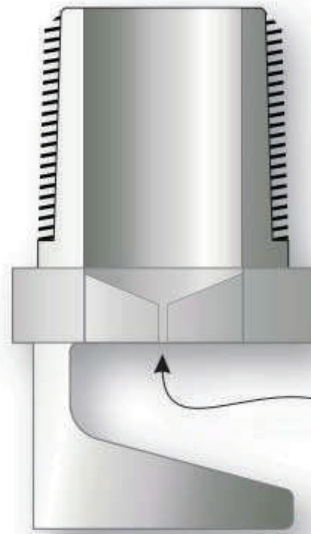

Nozzle orifice sized to suit design requirements



7/8 AF

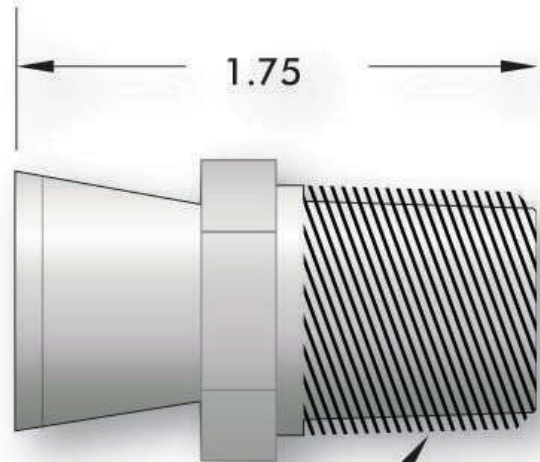

1.75

1/2" NPT

# High Pressure CO2 Fire Protection S-Type Discharge Nozzle

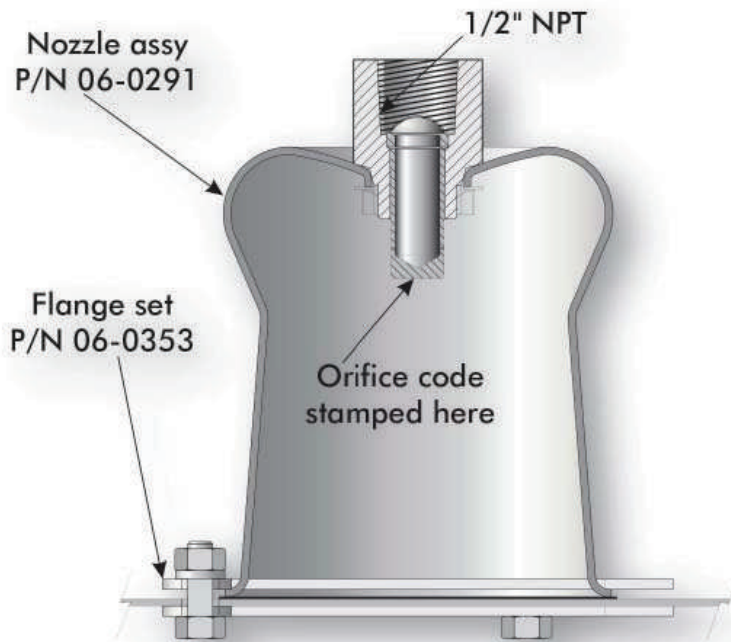

Height ft.	Flow Rate (lb per min.)	Area of Coverage (sq. ft.)
1	16	5.0
2	24	7.0
3	32	8.7
4	41	10.7
5	49	12.6
6	57	14.5
7	66	15.0
8	74	15.0

Nozzles up to and including #5 orifice are equipped with strainers.

Materials: horn - steel ni pltd  
insert & body - brass  
flanges - steel ni pltd

Flange set consists of two flanges, seal, 3 nuts, bolts 7 washers. Ordered as a set.

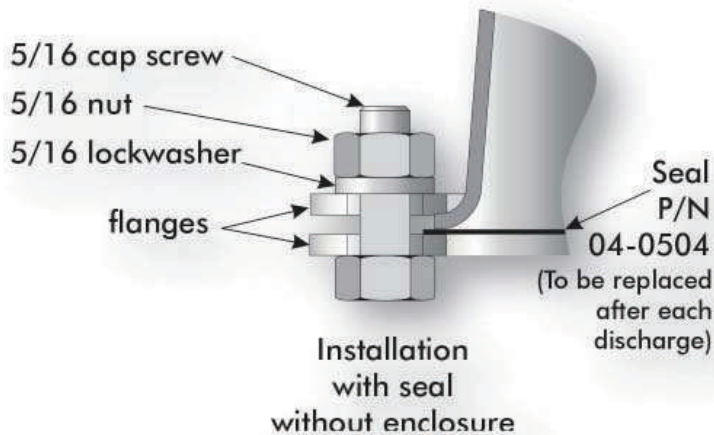
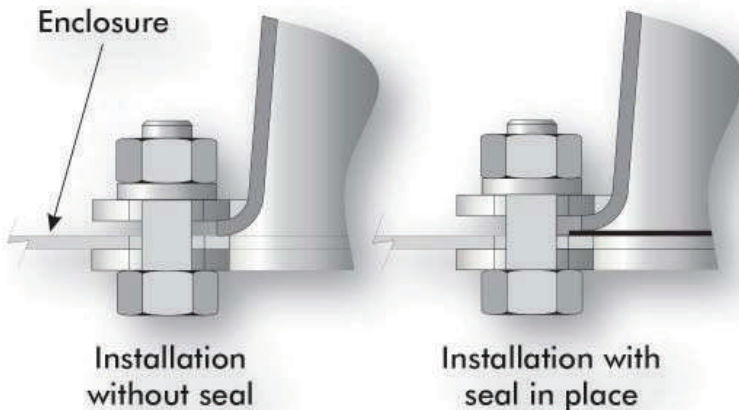

## Installation

1. Cut a 3-5/8" dia. hole in side of enclosure where shown on system drawing. Drill three 3/8" holes for cap screws using a clamping flange as a template.

2. If hazard is totally enclosed (i.e. In an air duct), cut a hand hole adjacent to nozzle for access for nut and bolt fixing. (Cover hand hole after nozzle installation.)

# High Pressure C02 Fire Protection Changeover Switch

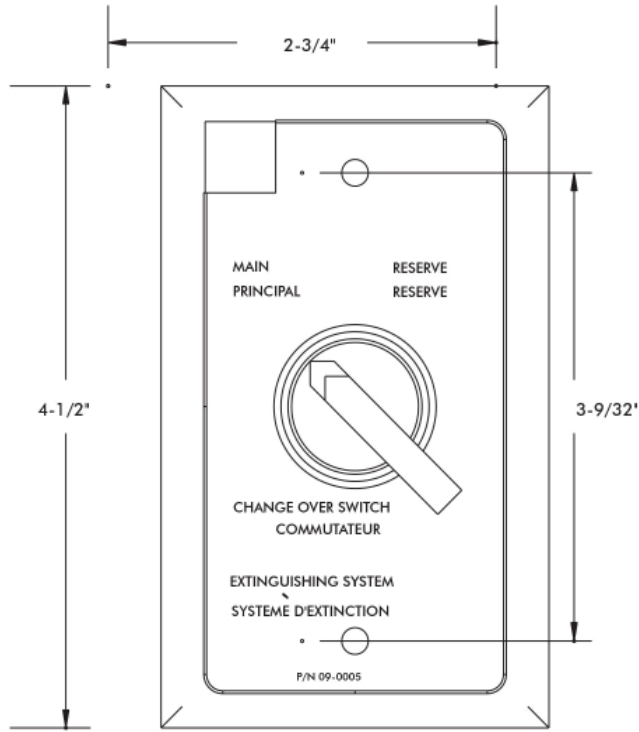

**P/N 09-0005**

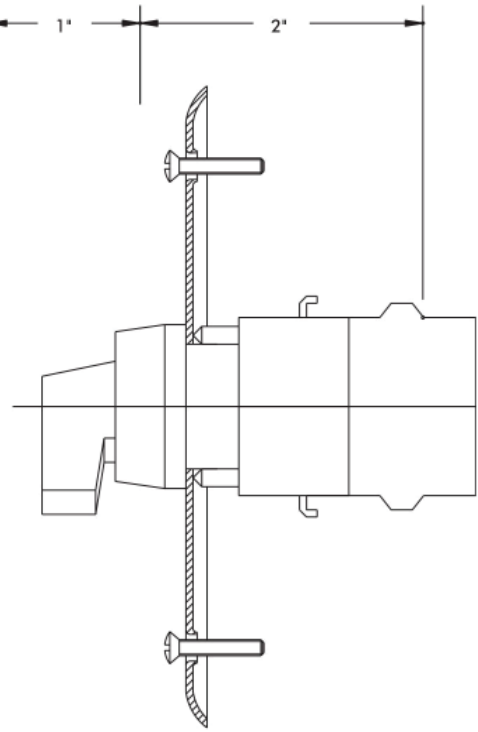

Operation  
Mounting  
Finish  
Switch rating  
Wiring (lever pointing  
towards MAIN)

Rotate lever until it points towards the system required.  
Standard single gang extra deep box (suppued by installer).  
Stainless steel plate. Black lever.  
10 A at 24 VDC. 0.5 A at 220 VDC. 10 A at 300 VAC.  
Terminals 21 & 22 MAIN (N.C.)  
Terminals 13 & 14 RESERVE (N.O.)

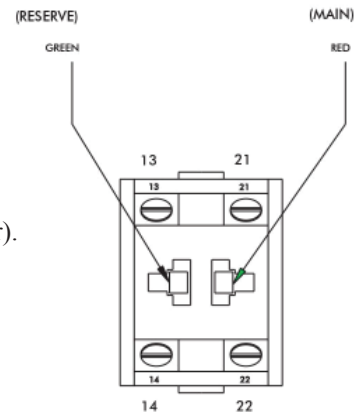

High Pressure CO2 Fire Protection

Vent Nozzle

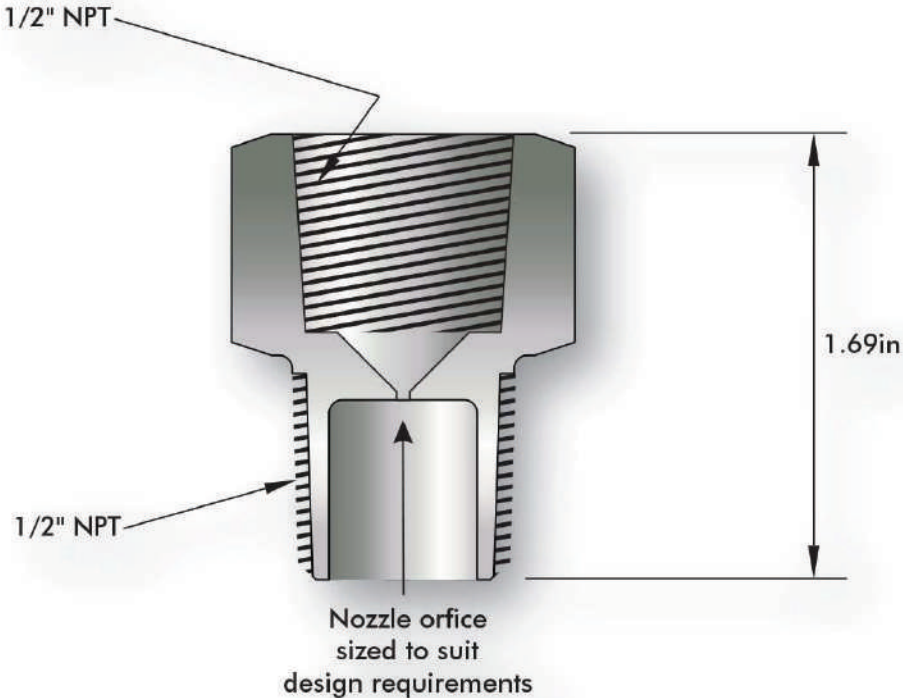
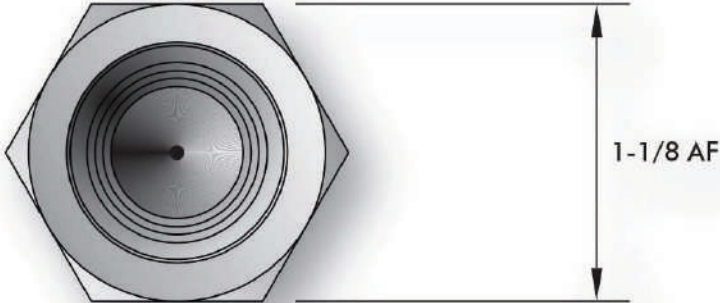

MATERIAL: BRASS

# High Pressure C02 Fire Protection Pressure Release Trip

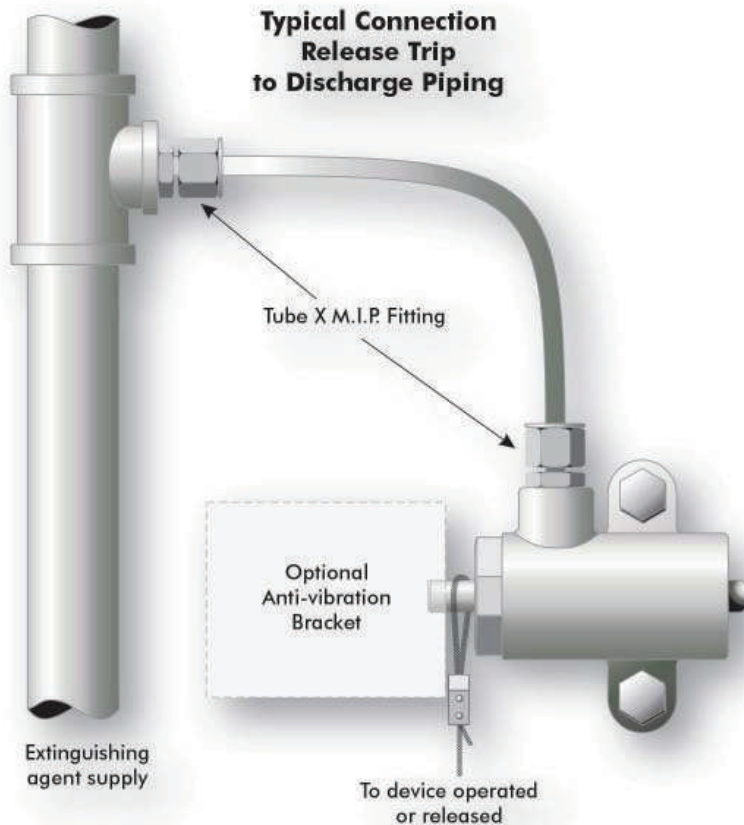
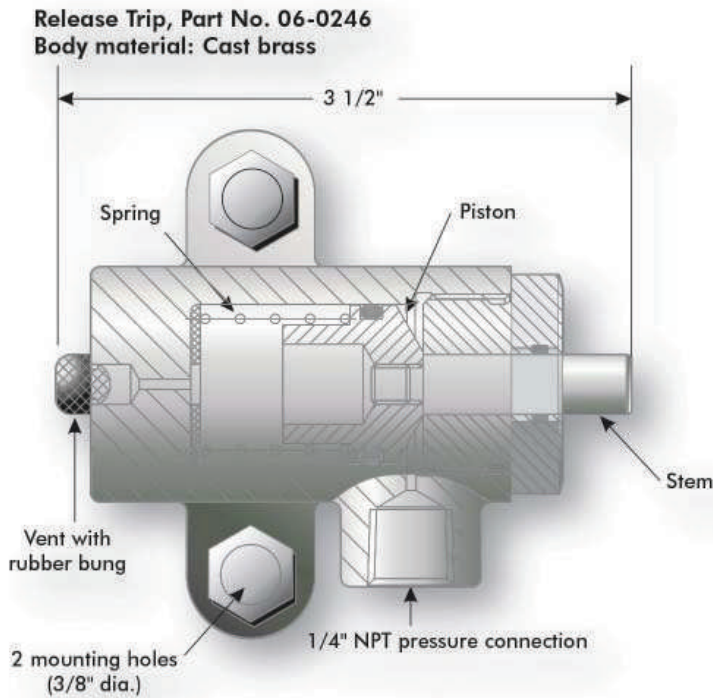

## Notes

These units are used to release dampers, doors, windows, louvres, to open dump valves, and to close fuel supply valves, etc. automatically when agent discharges.

The equipment to be operated must be weight or spring loaded, or be pivoted off-centre.

The pressure connection of the trip can be connected to the discharge piping of any cylinder in the system, to the rid valve pilot tubing, or to the nitrogen actuation tubing.

The maximum load that can be hung on the piston stem is 76 lb. (34 kg).

Connection can be made in 1/4" steel pipe, 1/4" or 3/16" x .032" wall soft copper tube. Swagelok, Gyrolok, or similar fittings are recommended for tube connections.

If additional release trips or pressure switches are required, install branch tees to suit.

# High Pressure C02 Fire Protection Pressure Release Trip

Pressure Switch, Part No. 06-0247

Double pole, double throw

Rating: 15 Amps, 120 Vac per pole

8 amps, 240 Vac per pole

1 HP, 120 Vac, 5 phase

Finish: Cadmium plated weatherproof enclosure

Pressure switches can be used to shut down motors, pumps, fans, or operate alarms, release doors, or provide confirmation of extinguishment system operation, etc. automatically when the extinguishing system discharges.

The pressure connection of the switch can be connected to the discharge piping of any cylinder in the system, or to the nitrogen actuation tubing, if used.

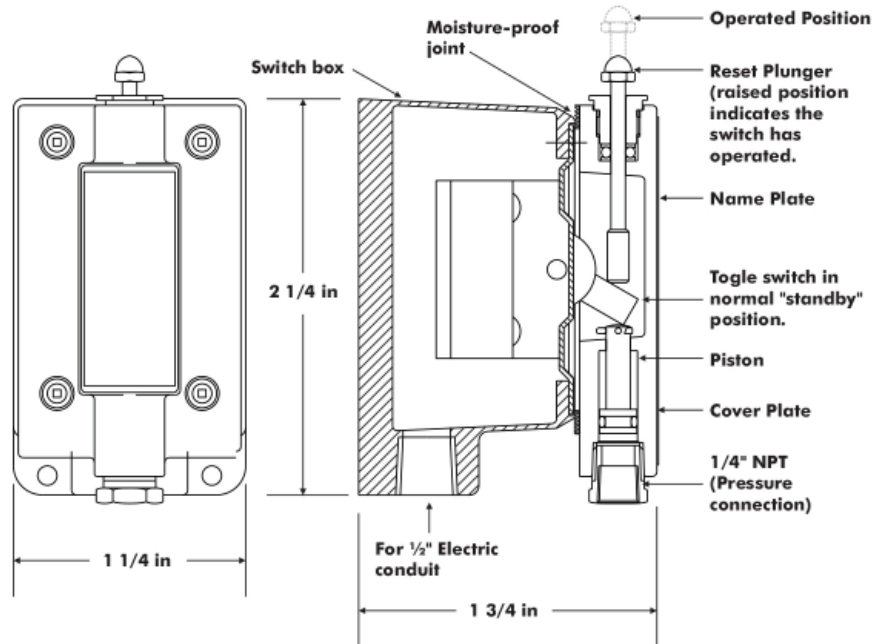

## Mounting and application

The switch may be mounted in any position, but the preferred installation is with the pressure connection (gas supply line) entering from the bottom.

Installation can be made using 1/4" steel pipe and fittings. Alternately, 1/4" or 3/16" x .032" wall soft copper tubing with swagelock or equal fittings can be used.

Note: When the line load is greater than the switch rating, the switch should be used to break a relay holding coil circuit (relay supplied by others).

## Testing

To test the circuits and to ensure auxiliary functions operate correctly:

Either..

1. Disconnect the union at the pressure connection, insert a small rod into the pressure connection of the cover plate, and push against the piston to trip the switch. Push the plunger down to reset the switch.

Or...

2. Remove the four cover screws and swing the cover away from the switch box. Manually operate the interior toggle switch. After testing, ensure the toggle is mounted in the normal standby position, then reinstall the cover plate.

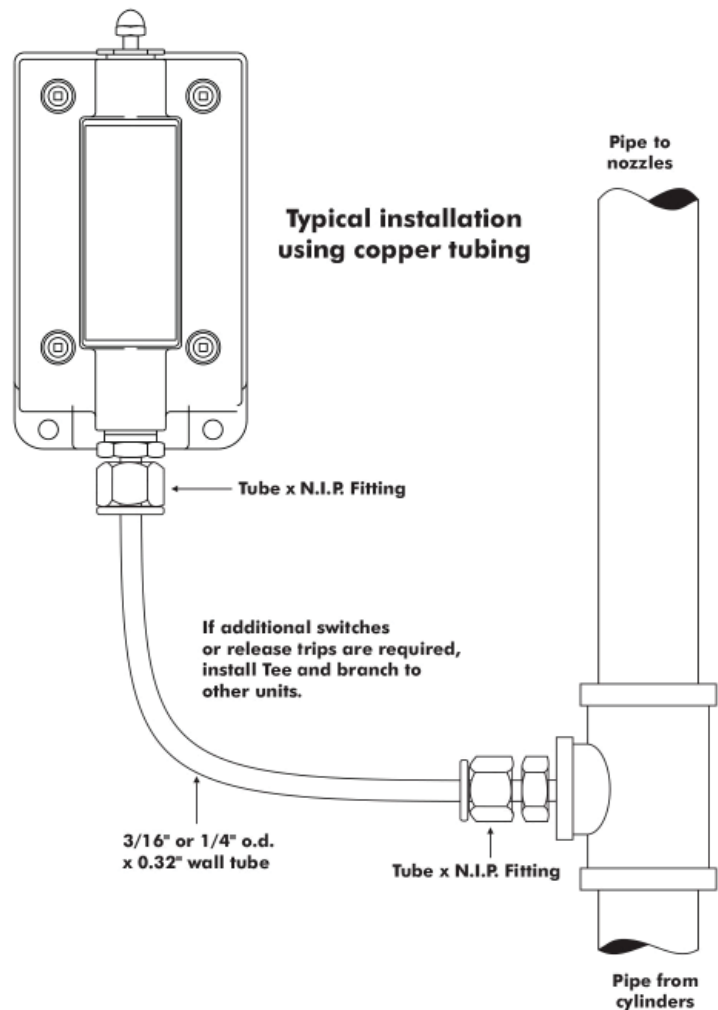

# High Pressure CO2 Fire Protection Cylinder Mounting Strap

Cylinder straps are intended to support floor mounted cylinders against a solid wall.

Only the strap is supplied by inControl Systems. All other components and mounting hardware is to be supplied by the installer to suit site conditions. Mounting bolts must be anchored into solid structural members. Bolts must not be anchored into plaster or other facing materials.

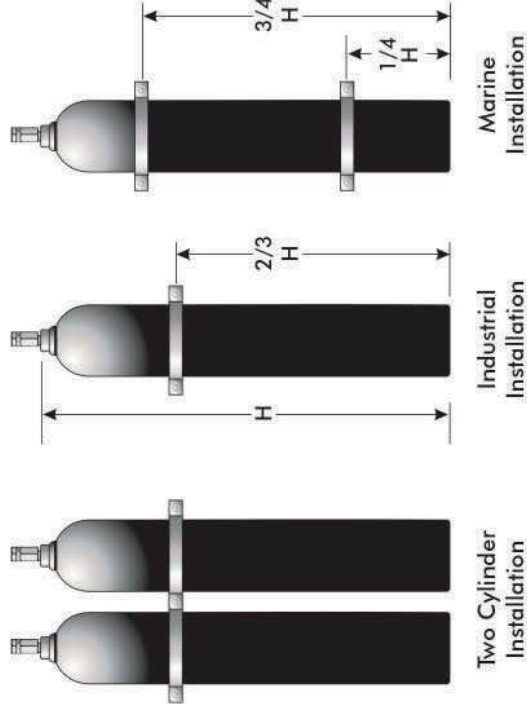
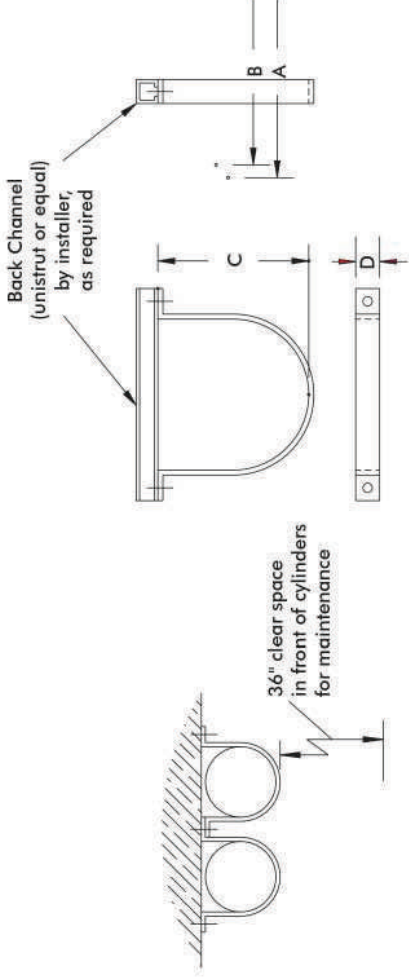

Part number	Cylinder dia.	Dimensions			
		A	B	C	D
04-0072	3.00	5.38	4.38	2.94	0.75
04-0073	4.26	6.63	5.62	4.19	0.75
04-0048	5.10	7.50	6.50	5.00	1.50
04-0332	6.73	10.05	8.80	6.57	1.50
04-0146	7.00	10.33	9.10	6.87	1.50
04-0049	7.10	9.50	8.50	7.00	1.50
04-0333	7.75	11.07	9.82	7.59	1.50
04-0147	9.06	12.33	11.08	8.85	1.50
04-0309	9.25	12.57	11.32	9.09	1.50
04-0201	10.00	13.33	12.08	9.85	1.50
04-0148	10.50	13.83	12.58	10.35	1.50
04-0212	12.38	15.13	14.13	12.20	1.50
04-0180	15.00	18.33	17.08	14.85	1.50
04-0227	16.00	19.33	18.08	15.85	1.50

## High Pressure C02 Fire Protection

# Remote Manual Control Application

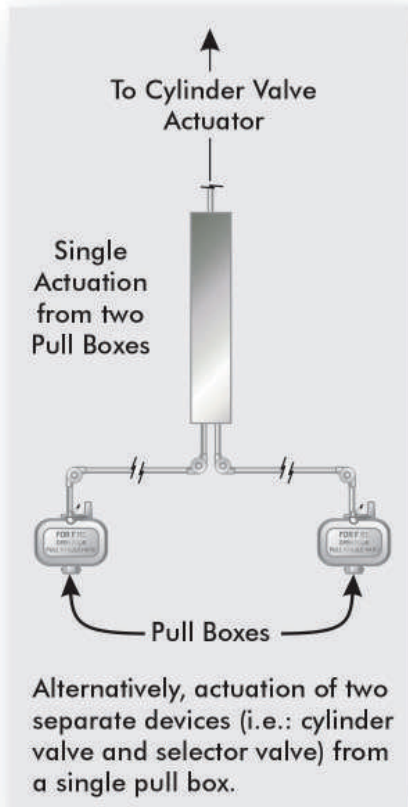
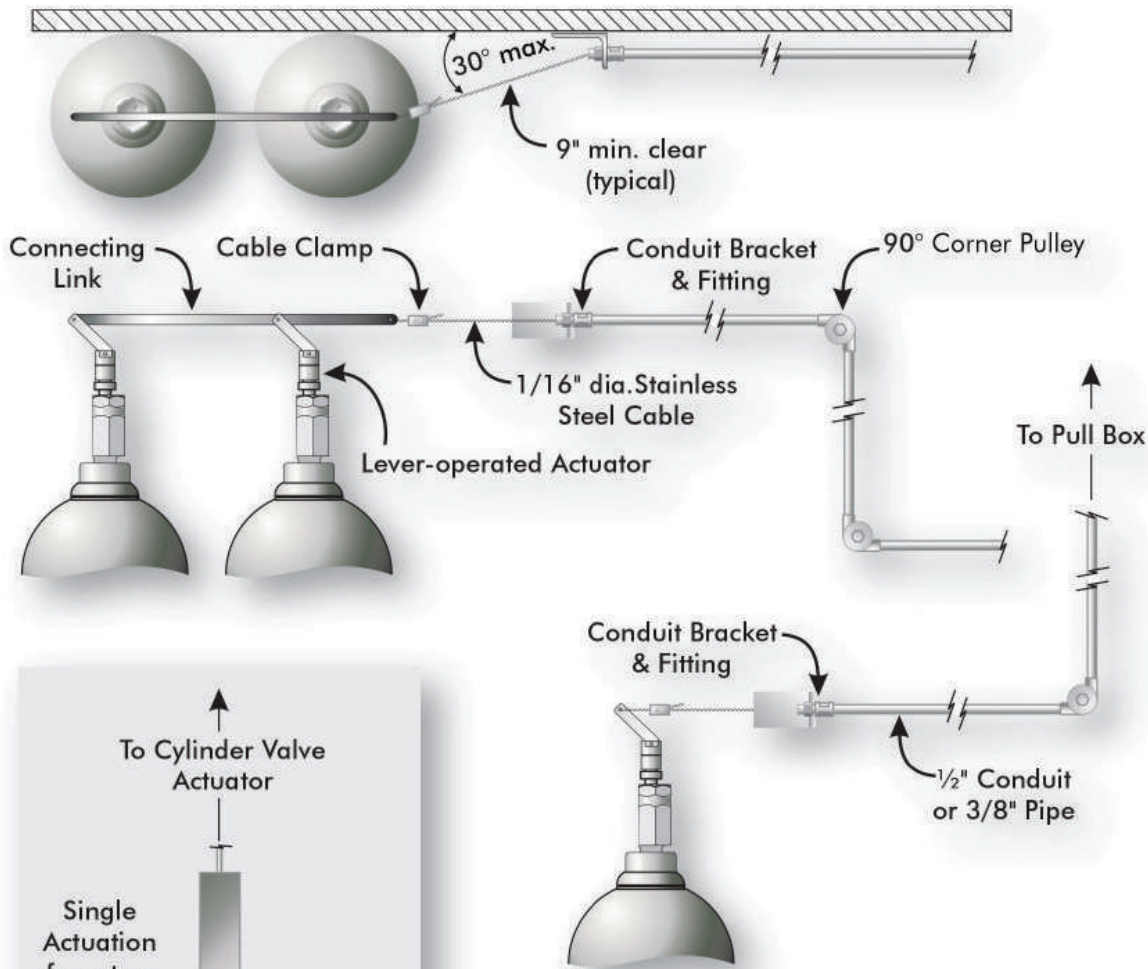

### Installation Notes

1. Run cable in 1/2" EMT conduit or 3/8" diameter pipe.
2. Install a corner pulley at each change in direction of cable
3. Covers of corner pulleys must be accessible after installation to allow removal for installation of cable.
4. Remote manual pull box should be installed three to five feet above floor level in a readily accessible location, and in the main egress from the protected space.
5. Ensure space in front of pull box will allow a straight pull of approximately nine inches.
6. Before starting to install the cable, ensure the safety pin is installed in the actuator(s).  
Remove the safety pin after completion of cable installation.
7. Maximum length of 1/16" stainless steel cable that can be installed is 500 feet.
8. Maximum number of pulleys that can be used:
  - a) on a single run is 15.
  - b) on a double run arrangement is 18, with a maximum of nine on any one leg.

# High Pressure CO2 Fire Protection

## Remote Manual Control Components

**90° Corner Pulley**  
Part No. 06-0245

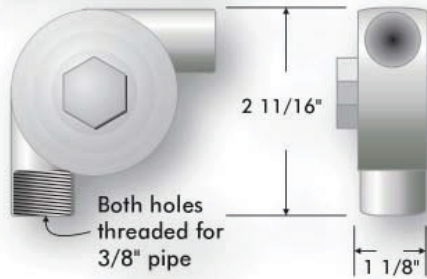

**Conduit Brackets**

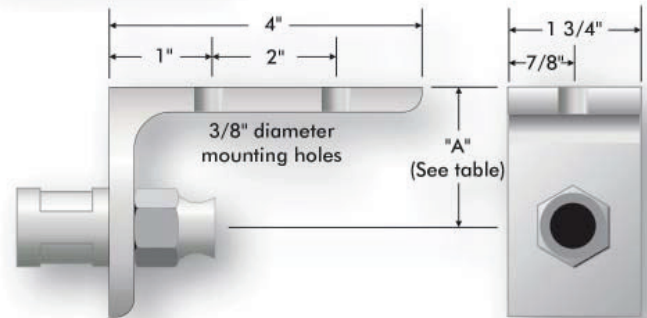

**Cable Clamp**  
Part No. 06-0012

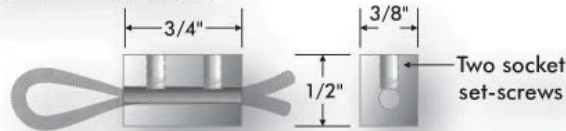

Conduit Bracket	Dimension "A"	Used on...
06-0257	1 3/4"	Small cylinders up to 20 lbs.
06-0248	2 1/2"	Large cylinders more than 50 lbs.

**Dual Junction**  
Part No. 06-0256

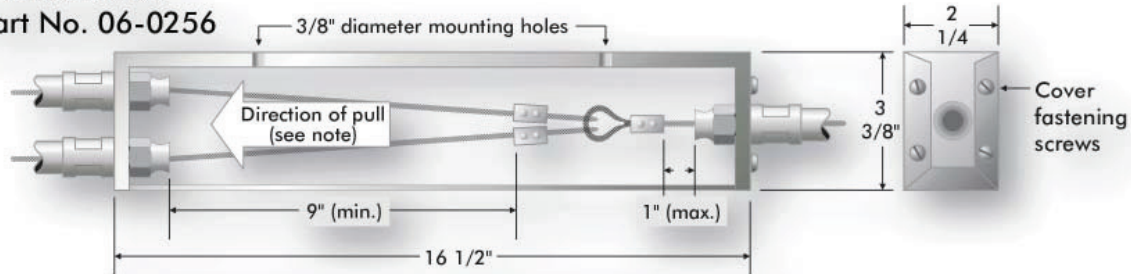

Note: to pull in the opposite direction, reverse the two boxed dimensions.

**Latch Type Pull Box**  
Part No. 06-0259

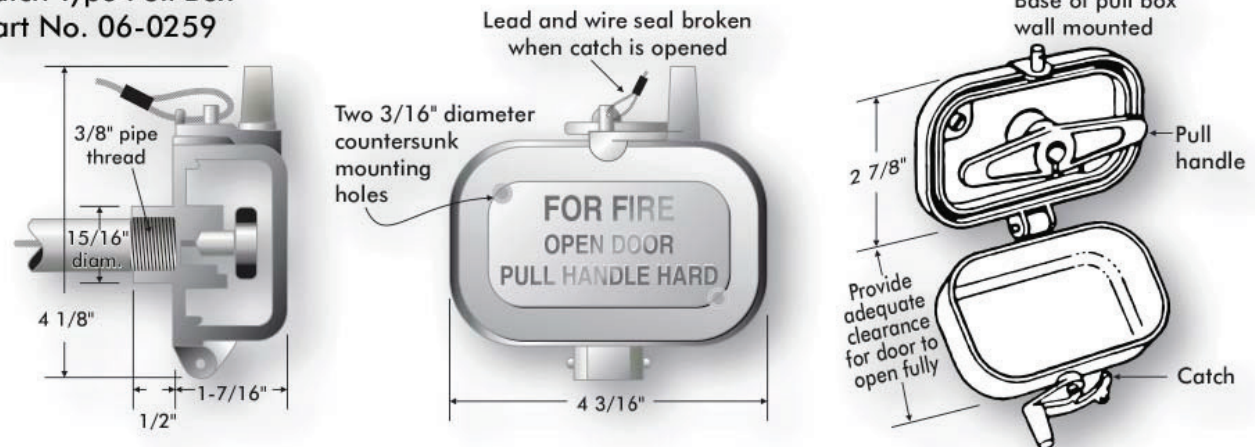

## High Pressure CO2 Fire Protection

# Selector Valves

### Selector Valves

Selector valves are used in specific cylinder arrangements to allow the protection of multiple hazards or hazard zones by one set of HPCO2 cylinders or where a time delay is required. InControl Systems HPCO2 selector valves are available as 1/2 in (15 mm) through 2 in (50 mm) pneumatically actuated ball valves or a 3 in (80 mm) pneumatically actuated wafer valve. Optional solenoid and lockout with proximity switch are available. Refer to Appendix A for part numbers and ordering information.

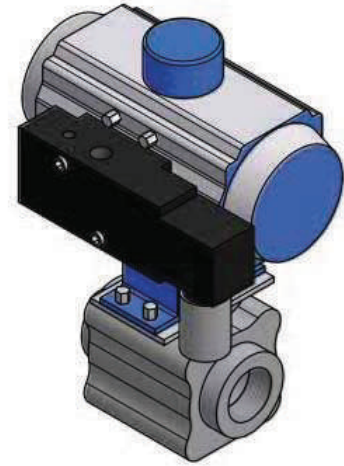

Selector Valve

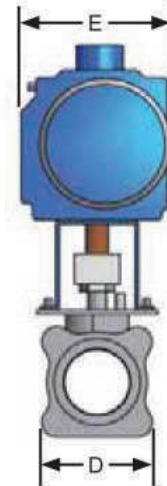
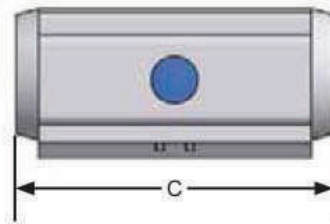
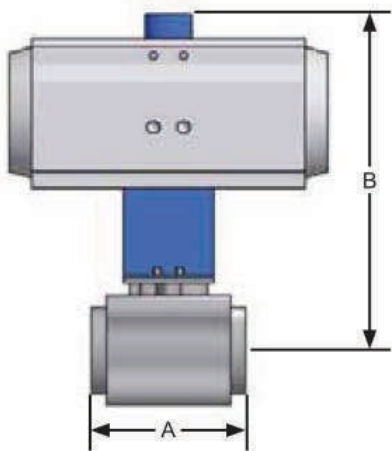

Pneumatically Actuated Ball Valve Dimensions													
P/N	Valve Size		Dimensions										
			A		B		C		D		E		
	in	mm	in	mm	in	mm	in	mm	in	mm	in	mm	
06-0755	1/2	15	2.59	66	6.73	171	5.53	140	2.06	52	2.77	69	
06-0756	3/4	20	3.01	76	7.17	182	6.24	158	2.25	57	3.27	83	
06-0757	1	25	3.69	94	7.46	189	6.24	158	2.59	66	3.27	83	
06-0758	1-1/2	40	4.58	116	10.56	268	9.74	247	3.33	85	4.19	106	
06-0759	2	50	5.11	130	11.22	285	10.57	268	3.66	93	4.84	123	

## High Pressure CO2 Fire Protection

# Test Unit, 24 VDC Solenoid Valve

Attach connector cable here. LED will light when solenoid circuit is activated.

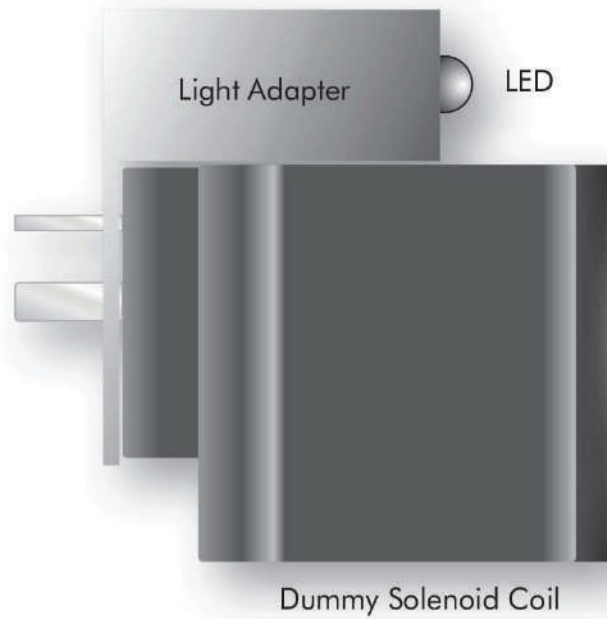

This unit is insensitive to polarity and is equipped with VDR protection against over-voltages when switching off.

# High Pressure C02 Fire Protection Manual Station with Uvex Cover

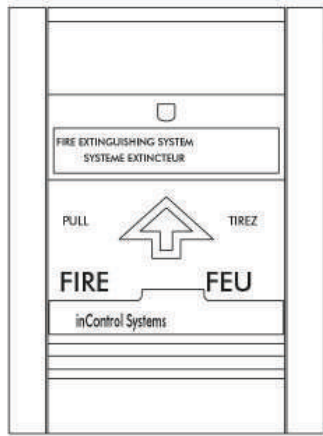

Manual Station

7/8"      1-7/8" STD.  
1-1/4" MIN.

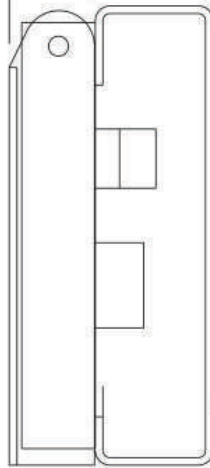

Surface Box  
P/N 05-0020  
(optional)

Contact arrangement with  
Manual Station in  
"Normal" position

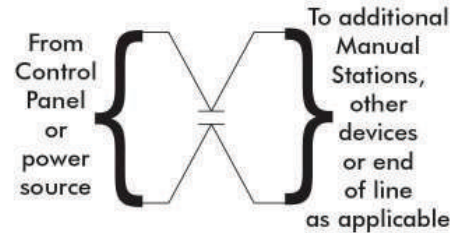

**Note**

For connection details and end-of-line value where applicable, refer to control panel wiring data.

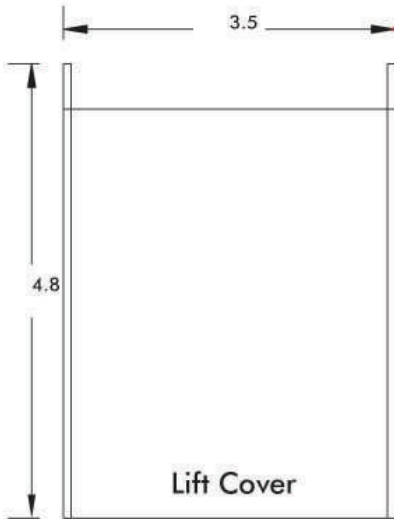

Clear UVEX Cover

To operate  
raise UVEX cover.  
Pull down front face  
of Manual Station.

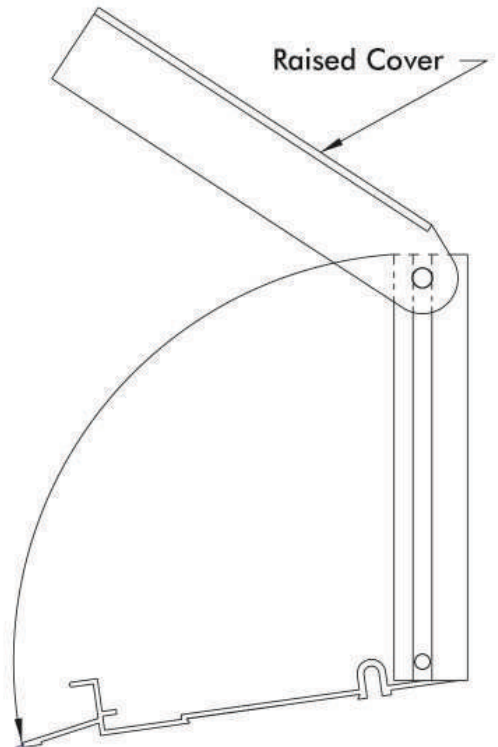

- Operation: Once pulled, the operating lever remains down and cannot be reset without a special tool.
- Mounting: semi flush - single gang
- Finish: red enamel
- Switch rating: 1 amp @ 30 VDC
- Part No.: 09-0003

## High Pressure CO2 Fire Protection

# CO2 Pressure/Temperature Curve

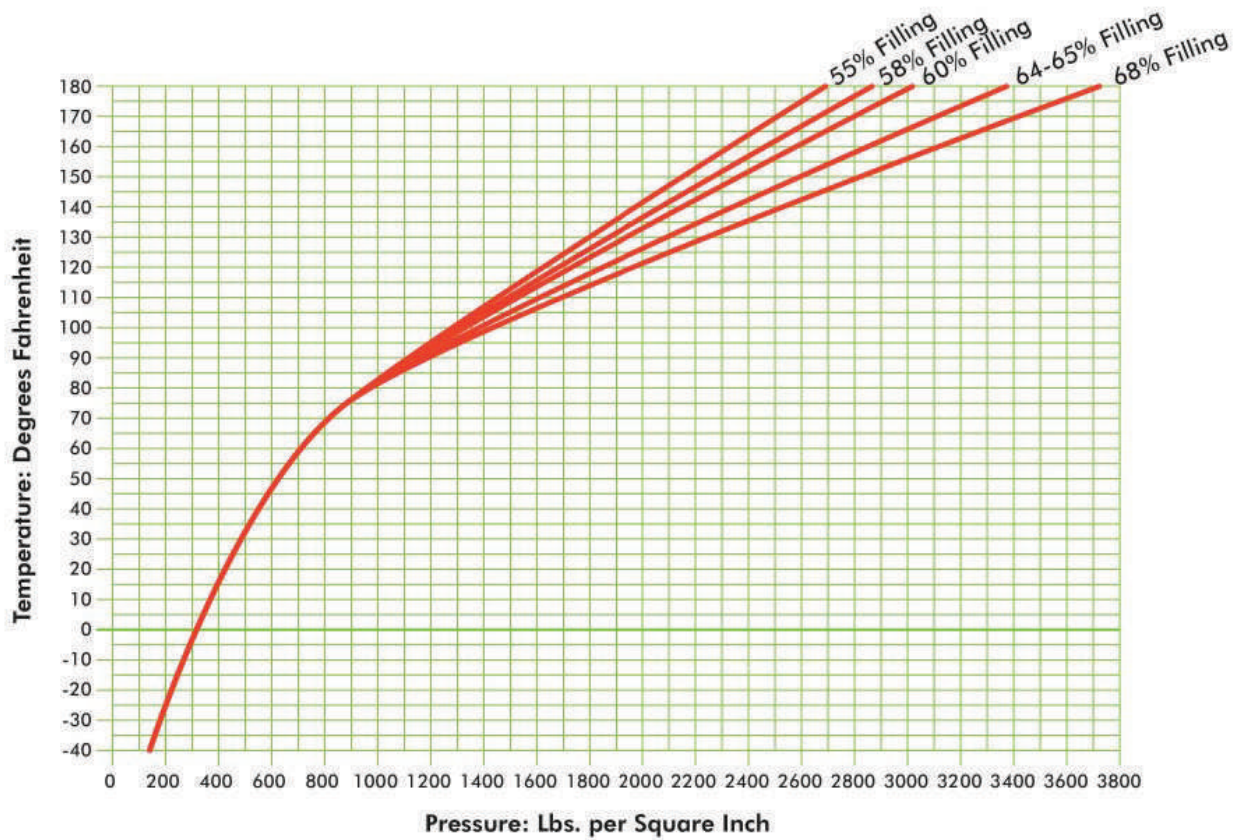

This curve shows the pressure in carbon dioxide cylinders at various temperatures when filled to a percentage of their water capacity.

In general, cylinders should not be filled to more than 68% or less than 60% of their water capacity. Cylinders currently supplied by inControl fire are filled to 68% of their water capacity.

$$\text{Percent filling} = \frac{\text{Lb. CO}_2 \text{ in cylinder}}{\text{Lb. water capacity of cylinder}} \times 100$$

High Pressure CO2 Fire Protection  
Door Warning Sign

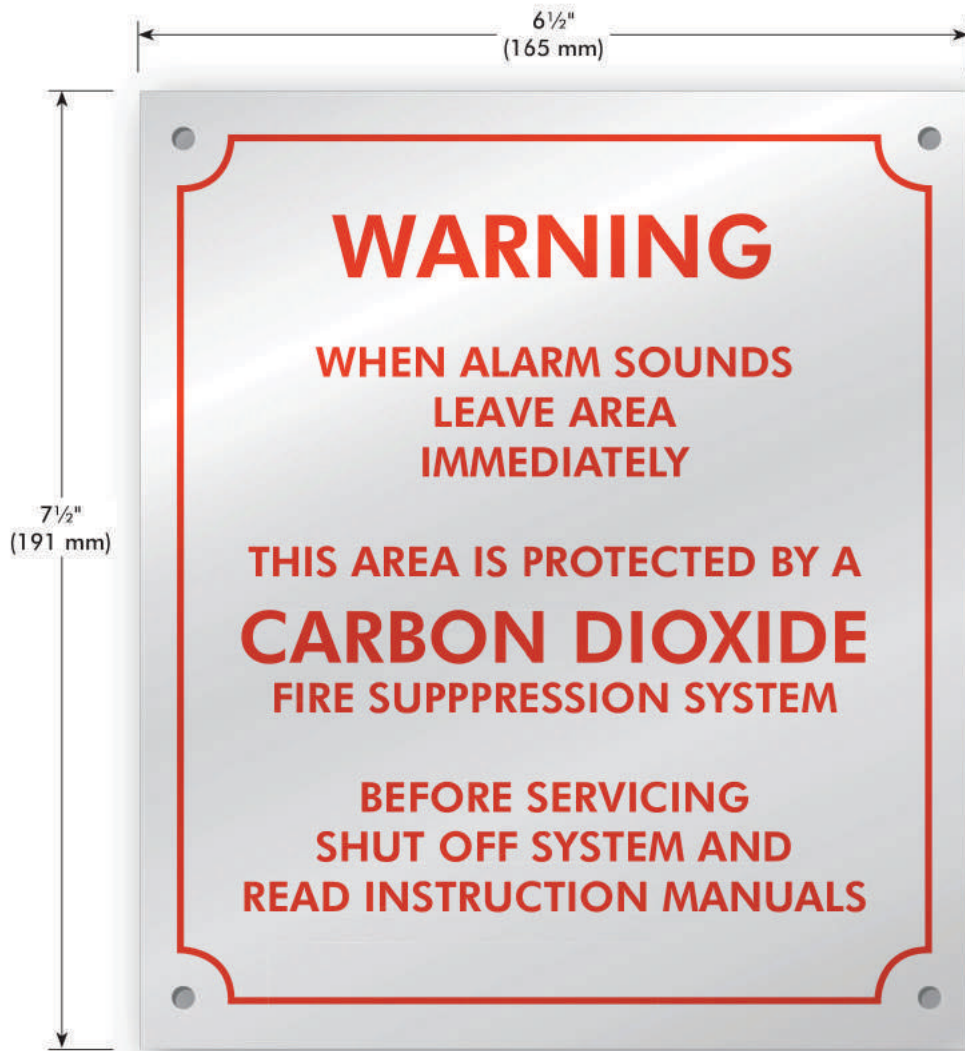

Part Number 12-0050  
Material: Aluminum  
Red lettering on natural background

# High Pressure C02 Fire Protection Gas Operated Siren

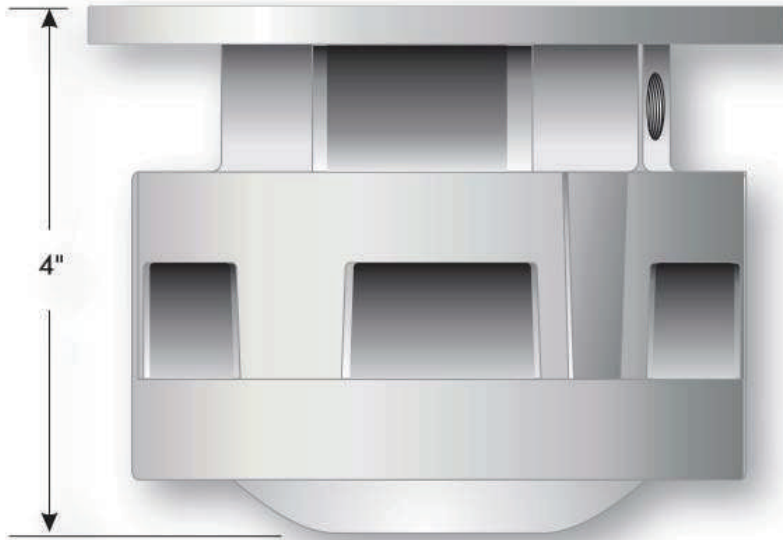

**Decibel Rating (at 10 Feet)**  
98 dB at 350 PSIG  
86 dB at 100 PSIG

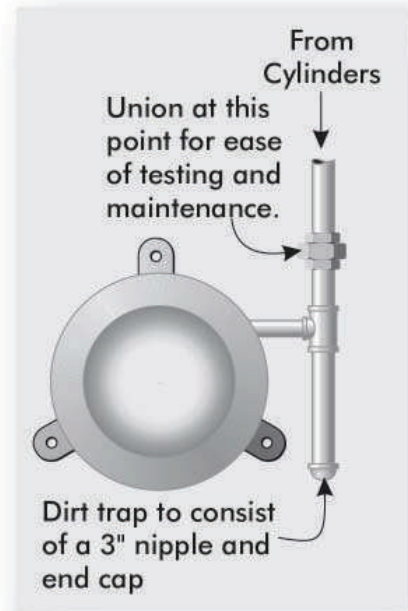

**Material**  
Housing & Impeller:  
Aluminum

Cover:  
Steel painted red

Three 3/16" diameter holes on 5 1/4" Circle, equally spaced

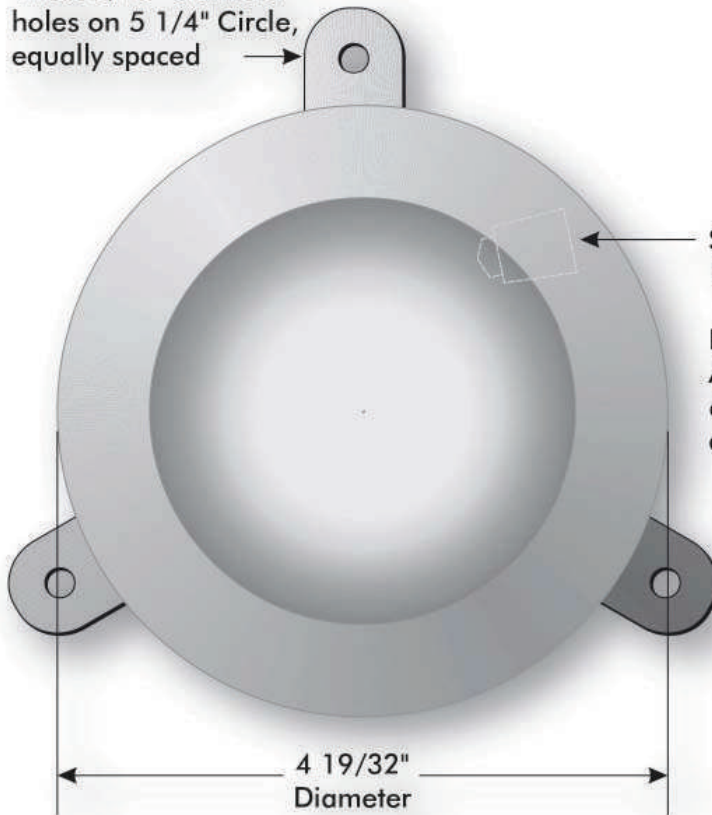

**P/N 06-0275**

High Pressure CO2 Fire Protection  
**Half-inch Header Safety**

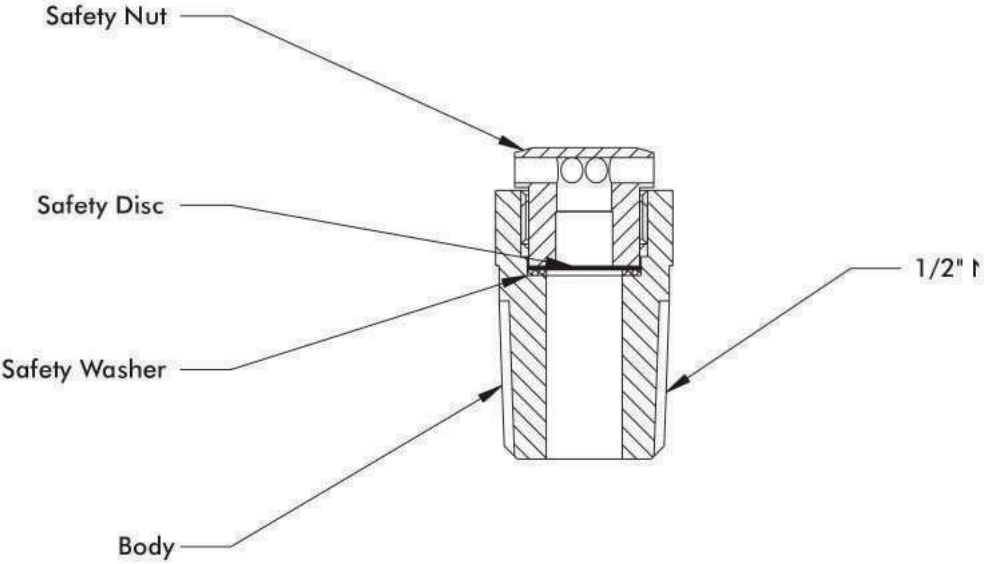
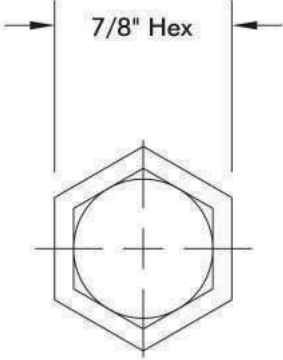

Bursting Pressure  
2650 to 3000 PSI

**P/N 06-0276**

## High Pressure CO<sub>2</sub> Fire Protection Bleeder Valve

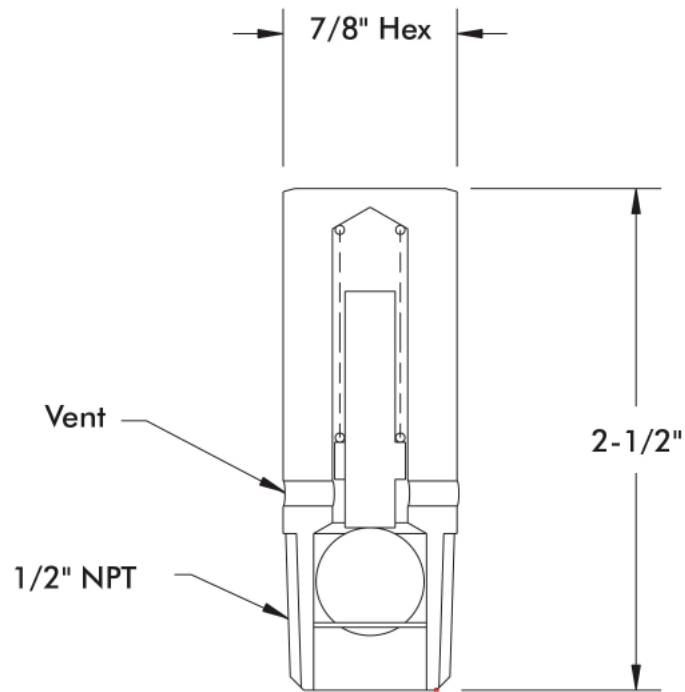

### **P/N 06-0343**

This bleeder valve is installed in main and reserve cylinder manifolds to vent accidental check valve leakage during discharge of one cylinder bank. If unvented, accumulated leakage pressure could cause actuation of the other cylinder bank. The valve closes when manifold pressure reaches approximately 20 PSIG to prevent agent loss under normal discharge conditions.

# High Pressure CO2 Fire Protection

## Typical Single-Cylinder Installation

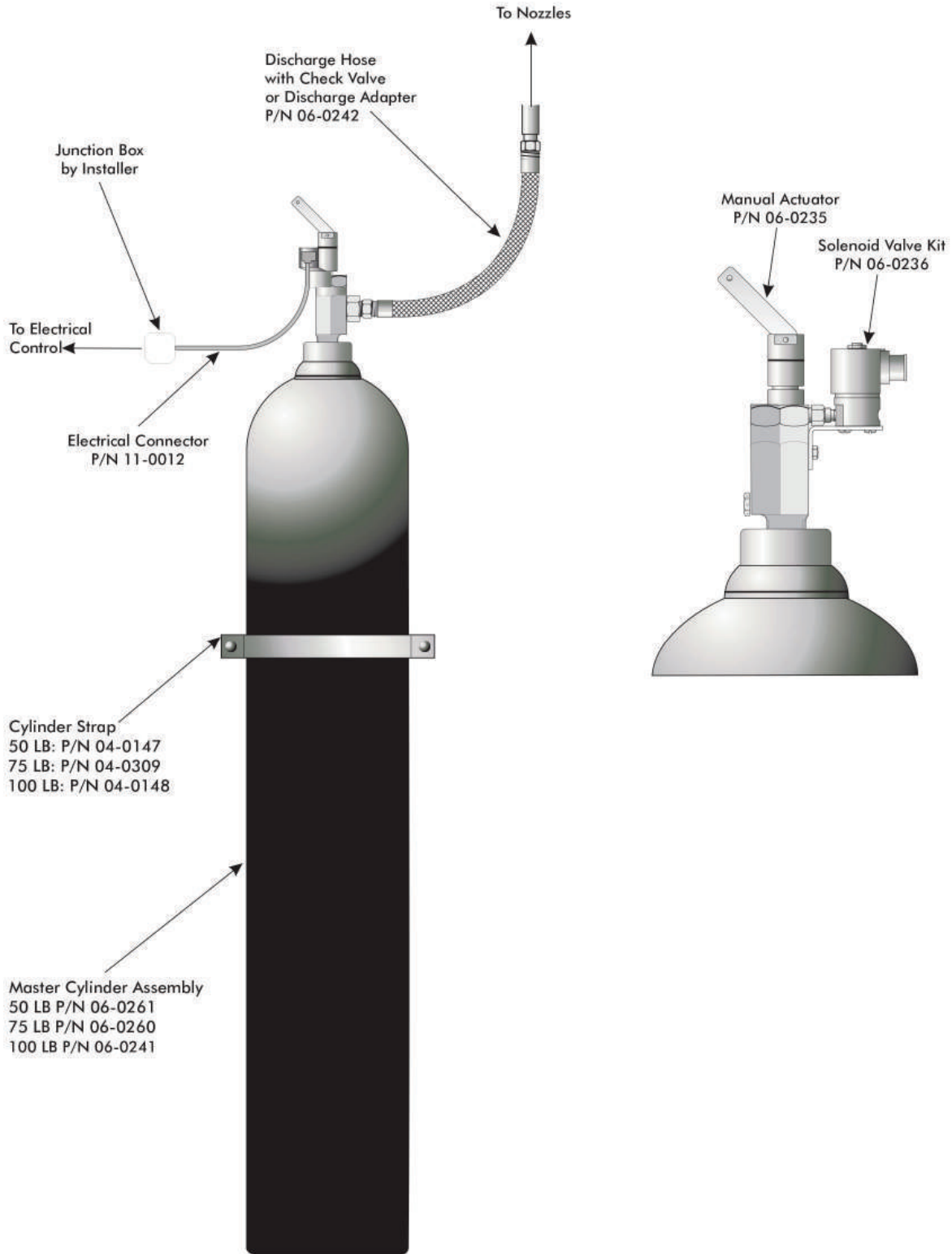

# Typical Two-Cylinder Installation

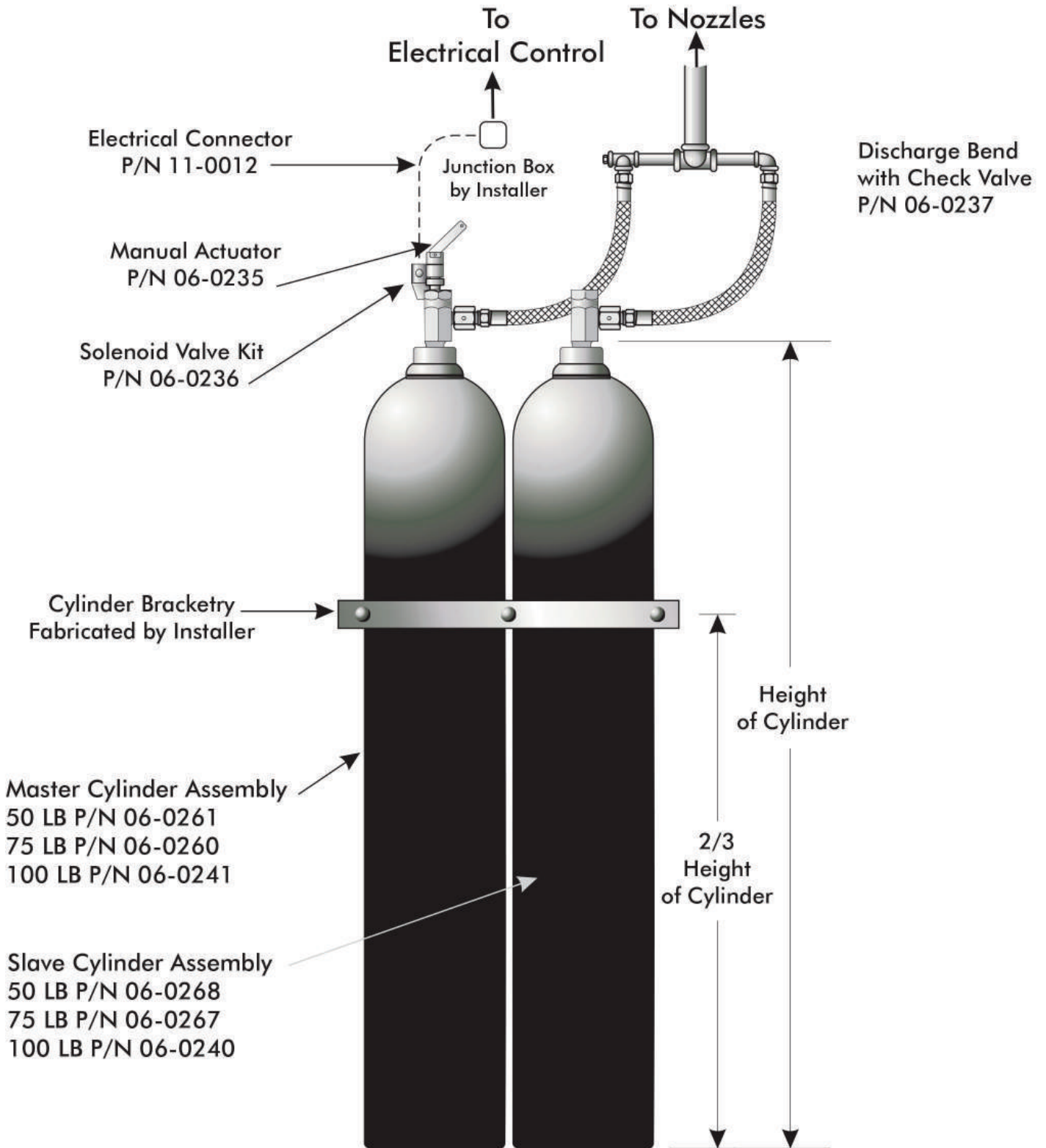

# High Pressure CO2 Fire Protection Typical Assembly, 100 lb. Cylinders

DATA SHEET

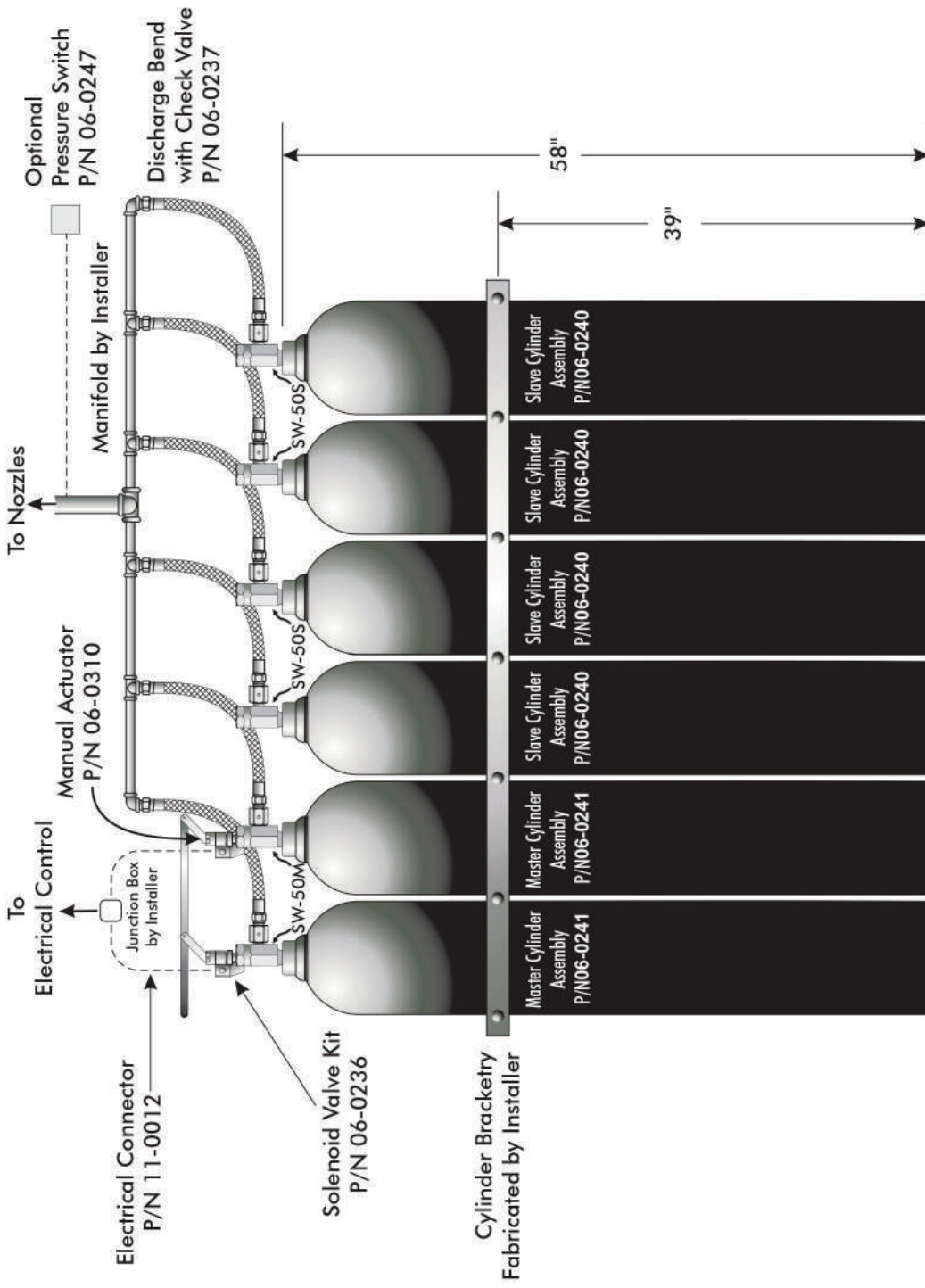

# Typical Main and Reserve Cylinder Installation

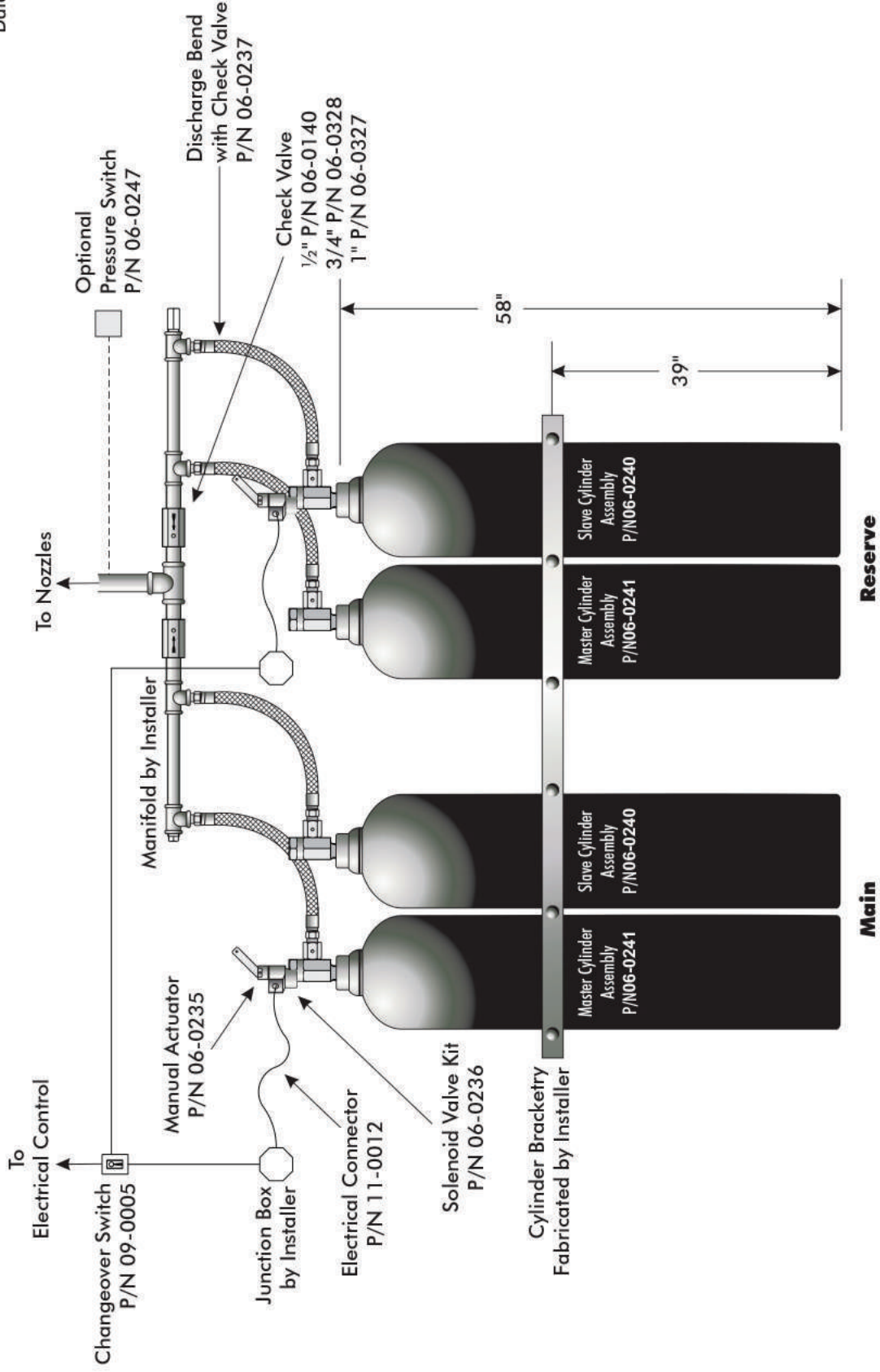

# High Pressure CO2 Fire Protection Typical Bracketing, Single Bank 100 lb. Cylinders

DATA SHEET

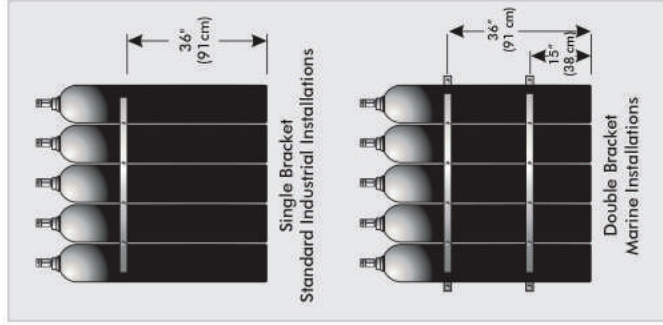
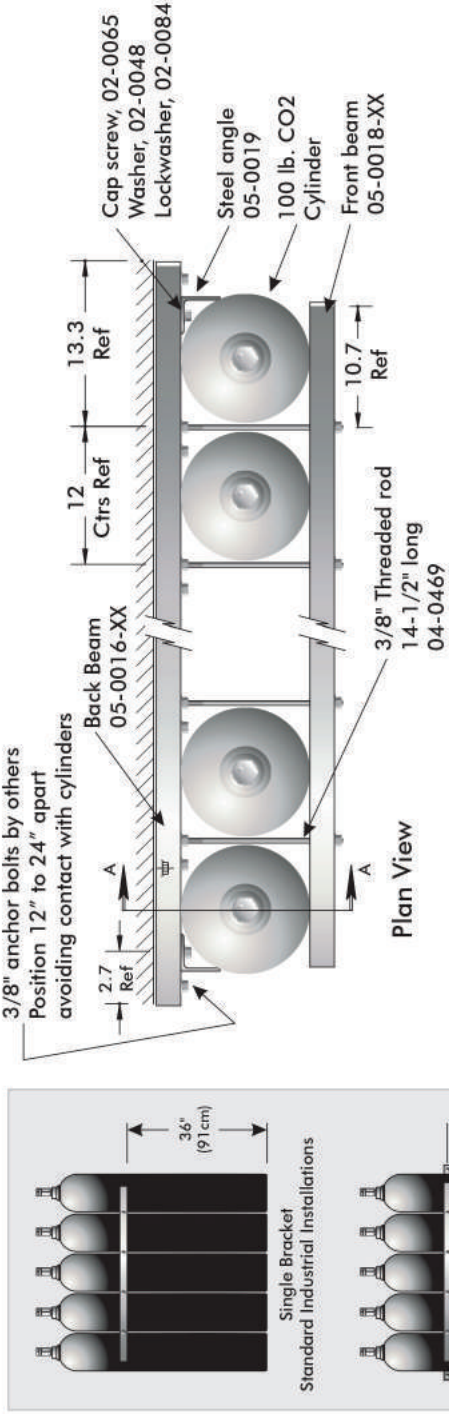

No. of pieces required for single bank set-up

No. of cylinders	2	3	4	5	6	7	8	9	10
Rod, 14-1/2", 04-0469	1	2	3	4	5	6	7	8	9
Angle, 05-0019	2	2	2	2	2	2	2	2	2
Captive nut, 02-0085	3	4	5	6	7	8	9	10	11
Plain nut, 02-0047	2	3	6	8	10	12	14	16	18
Plain washer, 02-0048	4	6	8	10	12	14	16	18	20
Lockwasher, 02-0084	4	6	8	10	12	14	16	18	20
Cap screw, 02-0065	2	2	2	2	2	2	2	2	2

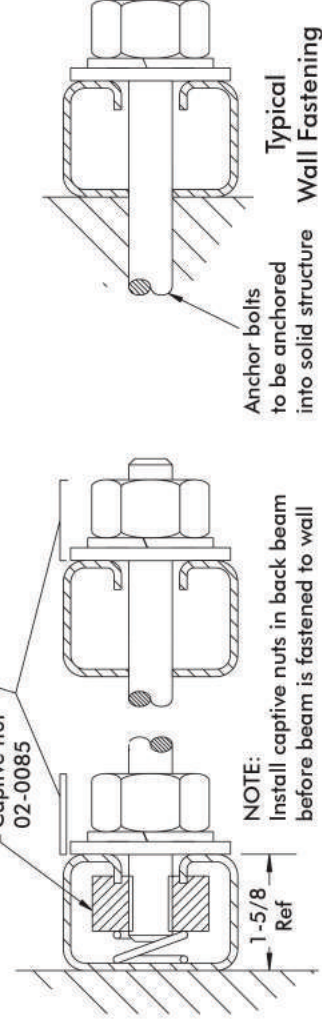

## Notes

1. XX of beam part no. indicates the number of cylinders.
2. Design is based upon the use of 1-5/8" technistrut beams and components, or similar.

# High Pressure C02 Fire Protection Typical Bracketing, Double Bank 100 lb. Cylinders

- Notes**
1. See 51-1054 for single bank.
  2. XX of the part no. for the two back beams indicates the number of cylinders between them.
  3. XX of the part no. for the front beam indicates the number of cylinders contained by the beam.
  4. Design is based upon the use of 1-5/8" technistrut beams and components, or similar.
  5. Part no. for the complete module is 51-1055-XX, where XX represents the total no. of cylinders.

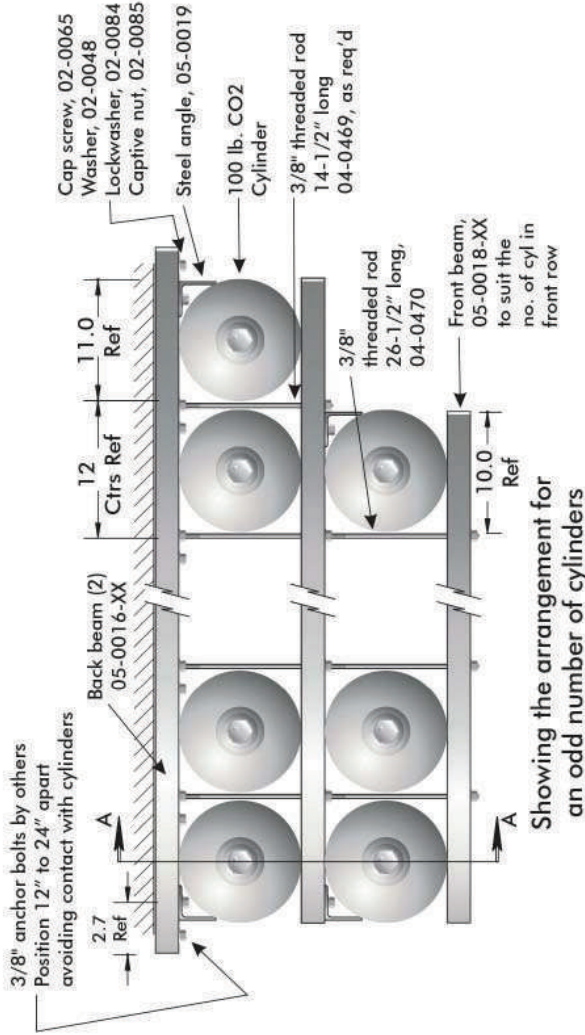

Showing the arrangement for an odd number of cylinders

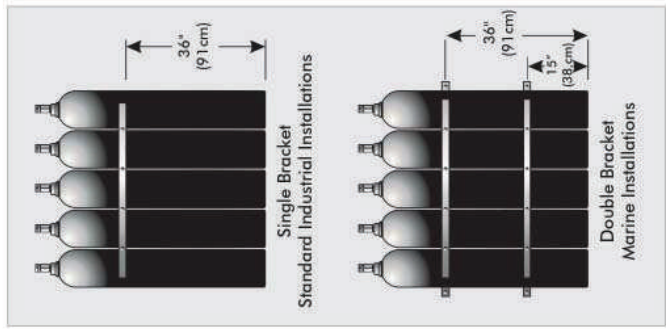

No. of pieces required for single bank set-up												
Total No. of cylinders	4	5	6	7	8	9	10	11	12			
Rod, 14-1/2", 04-0469	0	1	0	1	0	1	0	1	0	1	0	1
Rod, 26-1/2", 04-0470	1	1	2	2	3	3	4	4	5			
Angle, 05-0019	4	4	4	4	4	4	4	4	4	4	4	4
Captive nut, 02-0085	5	6	6	7	7	8	8	9	9			
Plain nut, 02-0047	3	5	6	8	9	11	12	14	15			
Plain washer, 02-0048	7	9	10	12	13	15	16	18	19			
Lockwasher, 02-0084	7	9	10	12	13	15	16	18	19			
Cap screw, 02-0065	4	4	4	4	4	4	4	4	4	4	4	4

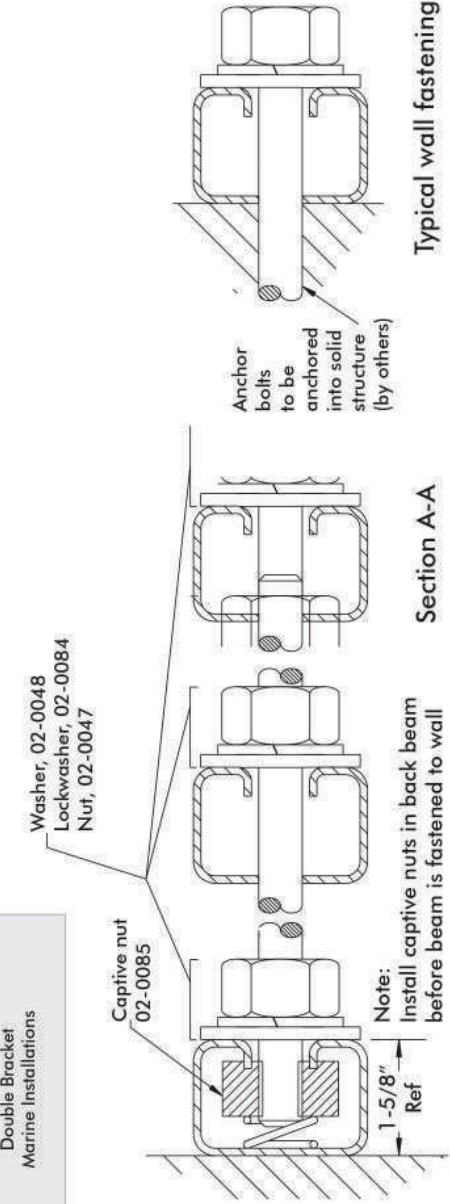

Section A-A

# High Pressure CO2 Fire Protection

## Typical Joint System with Main and Reserve Cylinders

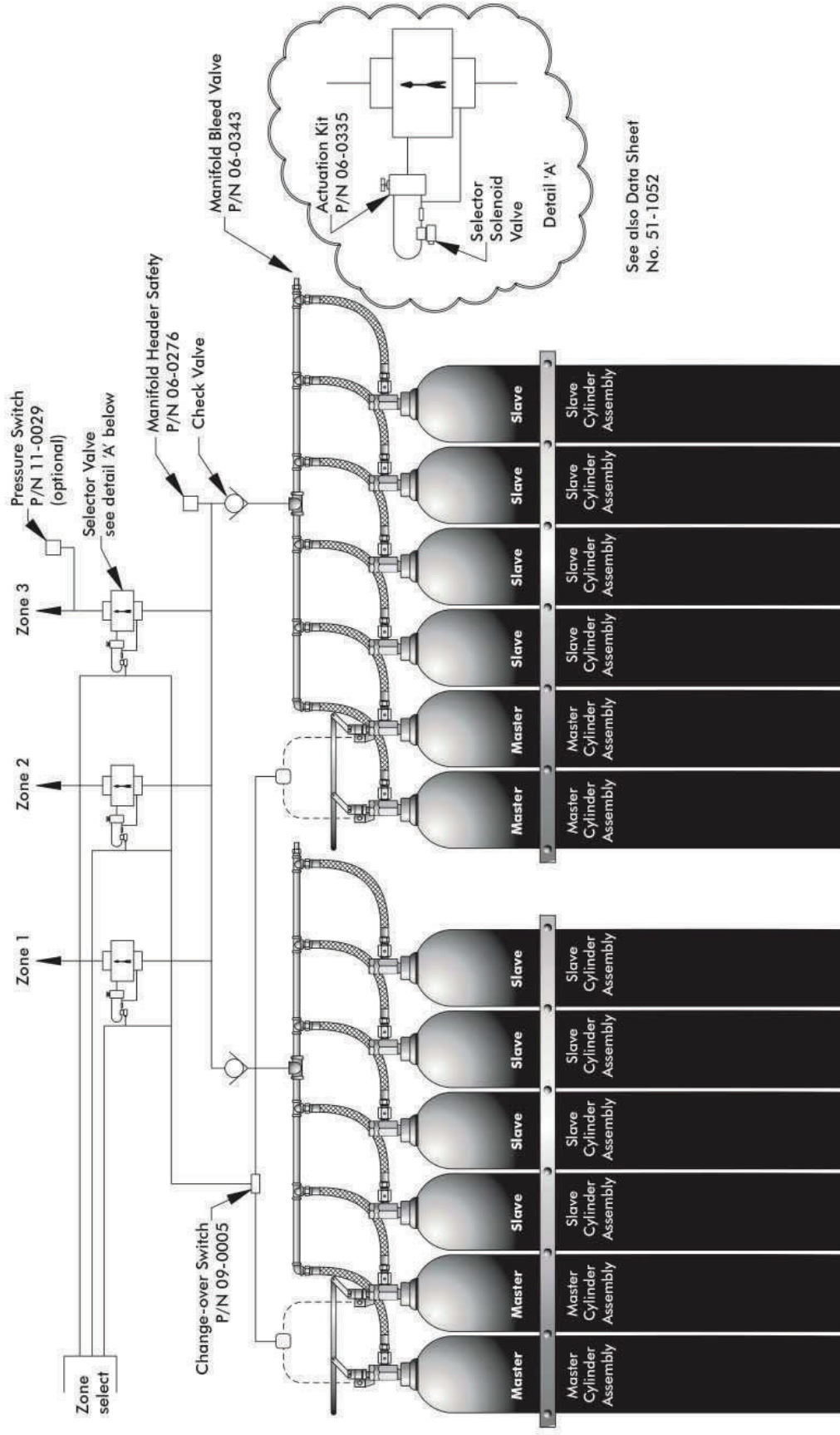

# High Pressure C02 Fire Protection Typical Installation with Gas Operated Sirens

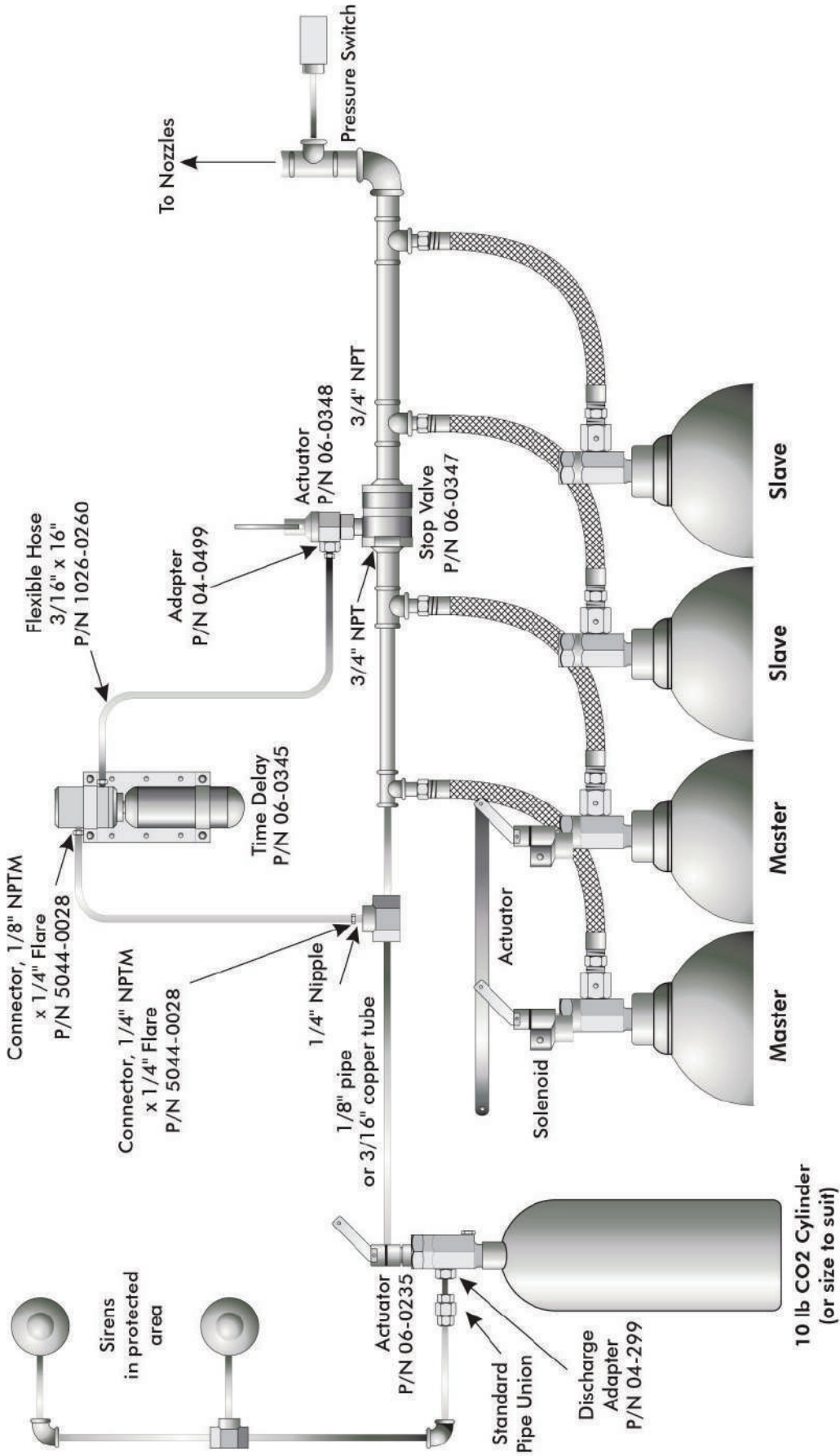

# High Pressure C02 Fire Protection Continuous Weigh Scale

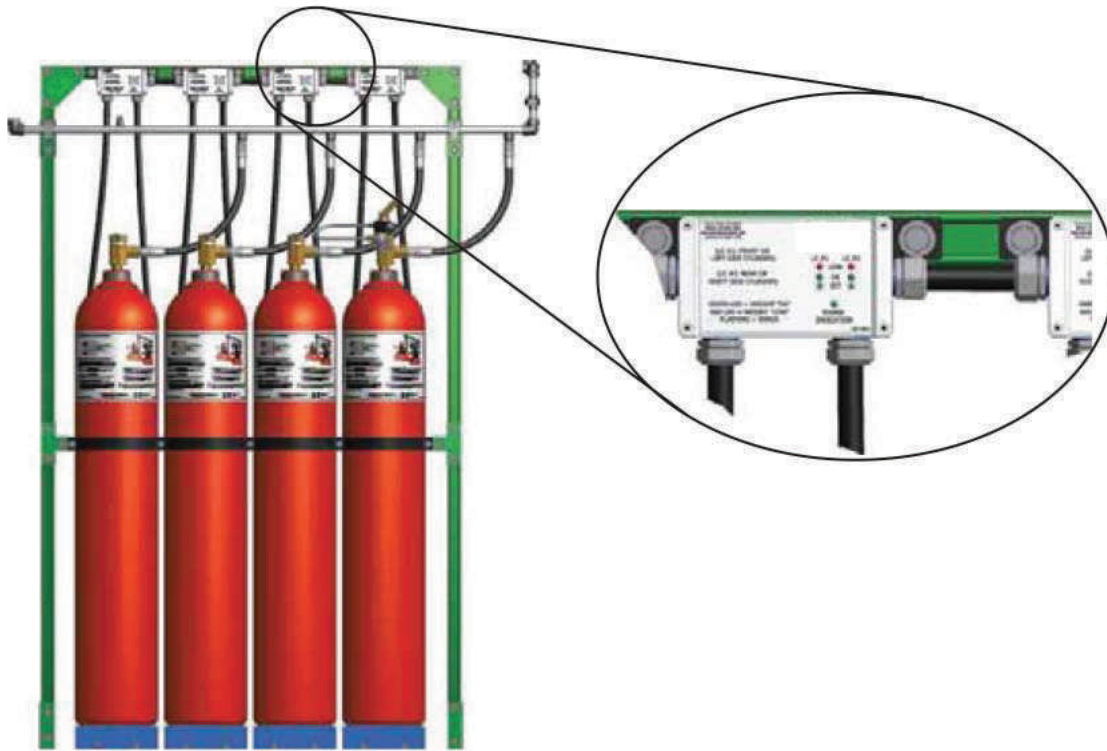

**Weight Scale Setup**

## BASIC OPERATION

The HPC02 Cylinder is placed on the center plate of the weight scale. The discharge hose is connected to the discharge manifold, and the solenoid valve, flex hose, and manual actuator is attached to the pilot cylinder. The conduit that is attached to the weight scale will run up the back of the rack and into the HPC02 dual display, which is attached to the top of the rack with a mounting flange and bolts. The dual display is designed to read up to two weight scales at a time. After the cylinder is placed on the weight scale along with all the other necessary components, the cylinder strap is tightened hand tight to the cylinder. The display is then powered on and the scale is tared to the gross weight of the cylinder. The dual display will then continuously monitor whether the weight of the cylinders is at an OK level or LOW level.

Continuous Weigh Scale Components			
P/N	Description	P/N	Description
06-0250	Display, Dual, Weight Scale, HPC02	06-0253	Load Cell, Weight Scale
06-0251	Flange Mount, for Dual Display	06-0254	Bolt, Hex Head Flange
06-0252	Twirl Nut, Strut	06-0255	Plug, Knockout

*Note: P/N 06-0250, 06-0251, 06-0254, 06-0252, and 06-0255 ship pre-assembled as P/N 06-0256*

## High Pressure CO2 Fire Protection



### DUAL DISPLAY (P/N 06- 0256)

The weight scale dual display is used to provide a visual indication that the cylinder gross weight is at the appropriate level (as indicated by the OK LED light) or below the appropriate level (as indicated by the LOW LED light). It has the capabilities to display the level for up to two weight scale load cells. A form C contact on the circuit board allows the user to wire the board to a PLC panel. The display is powered with 24 VDC and it has two sets of terminals on the board for power. One set is used to power the display and the second set is used to jumper to adjacent displays so power only has to be directly wired to one display coming from the power source. The display also has a large mount so it can be attached to the top unistrut rail on a HPC02 rack.

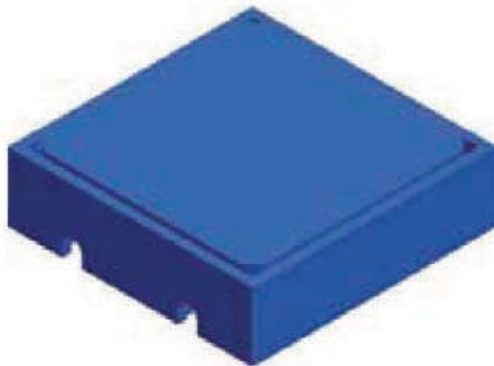

### WEIGHT SCALE LOAD CELL (P/N 06- 0253)

The HPC02 weight scale load cell is used to continuously monitor the gross weight of a HPC02 cylinder. Each load cell is 5 VDC excitation with a 2 mV/V output signal and a 660 lb [299 kg] capacity. A 126 inch [3200 mm] long, 3/8 inch [10 mm] liquid tight lexible metallic conduit runs from the load cell to the HPC02 dual display. There are two hole cutouts on each side of the weight scale wall to allow the user to run the lexible conduit underneath the weight scale. The front weight scale can run its conduit through the rear weight scale cutouts to prevent the conduit from getting damaged.

#### Order Review List

P/N	Description
06- 0256	Display, Dual, Weight Scale, HPC02, 24VDC, w/ Flange Mount
06- 0253	Load Cell, Weight Scale, HPC02, 5VDC Excitation, 2mV/V, 660 lb Capacity

Note: One Display (P/N 06-0256) is required for every two Load Cells (P/N 06- 0253) ordered. For example, 100 Load Cells would require 50 Displays. 101 Load Cells would require 51 Displays.

# High Pressure C02 Fire Protection Online Monitor (Analog Type)

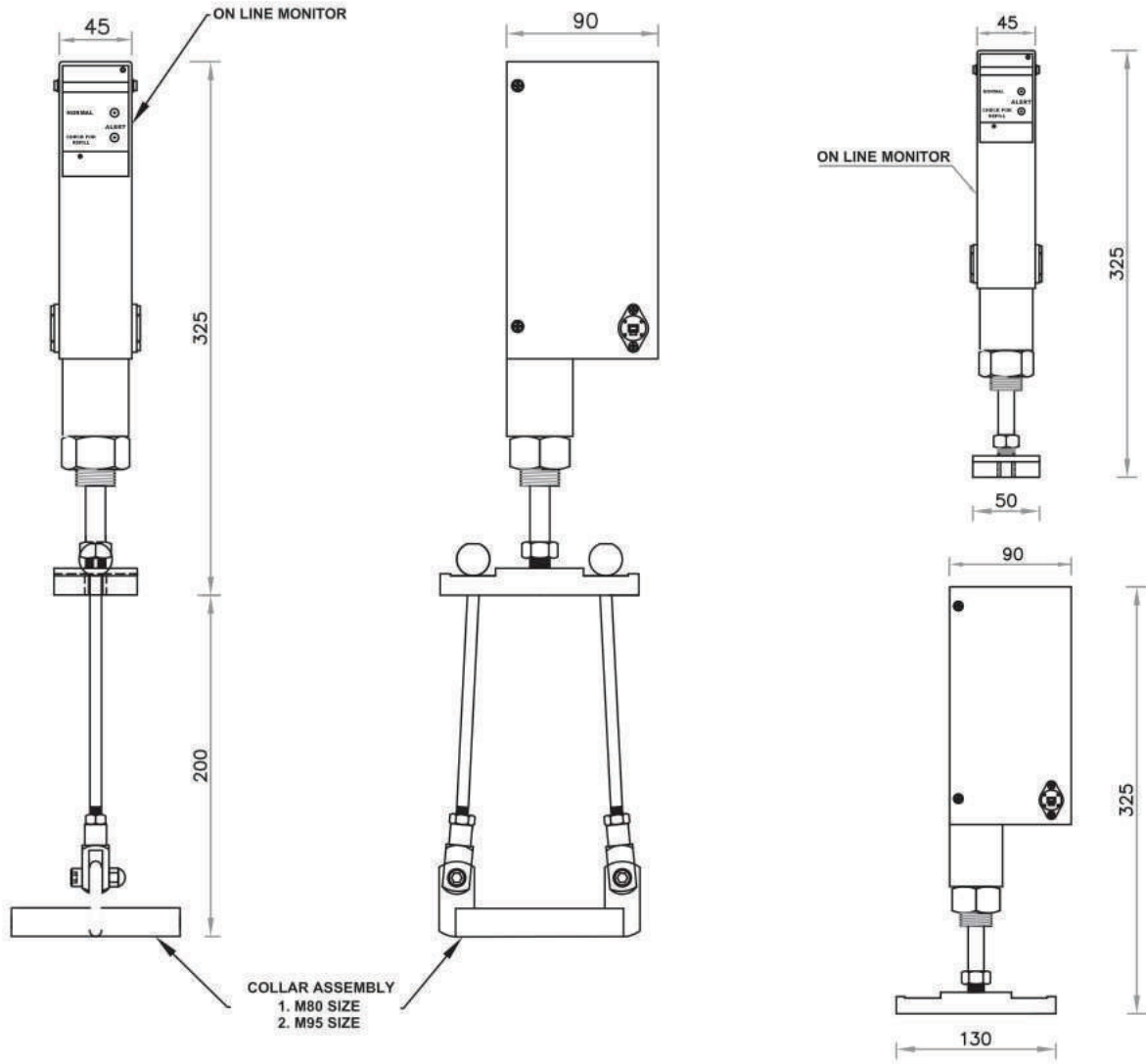

NOTE:  
Normal condition will be indicated by Green LED (Flashing). Alert will be indicated by Yellow LED.

# High Pressure C02 Fire Protection Online Monitor Control Panel

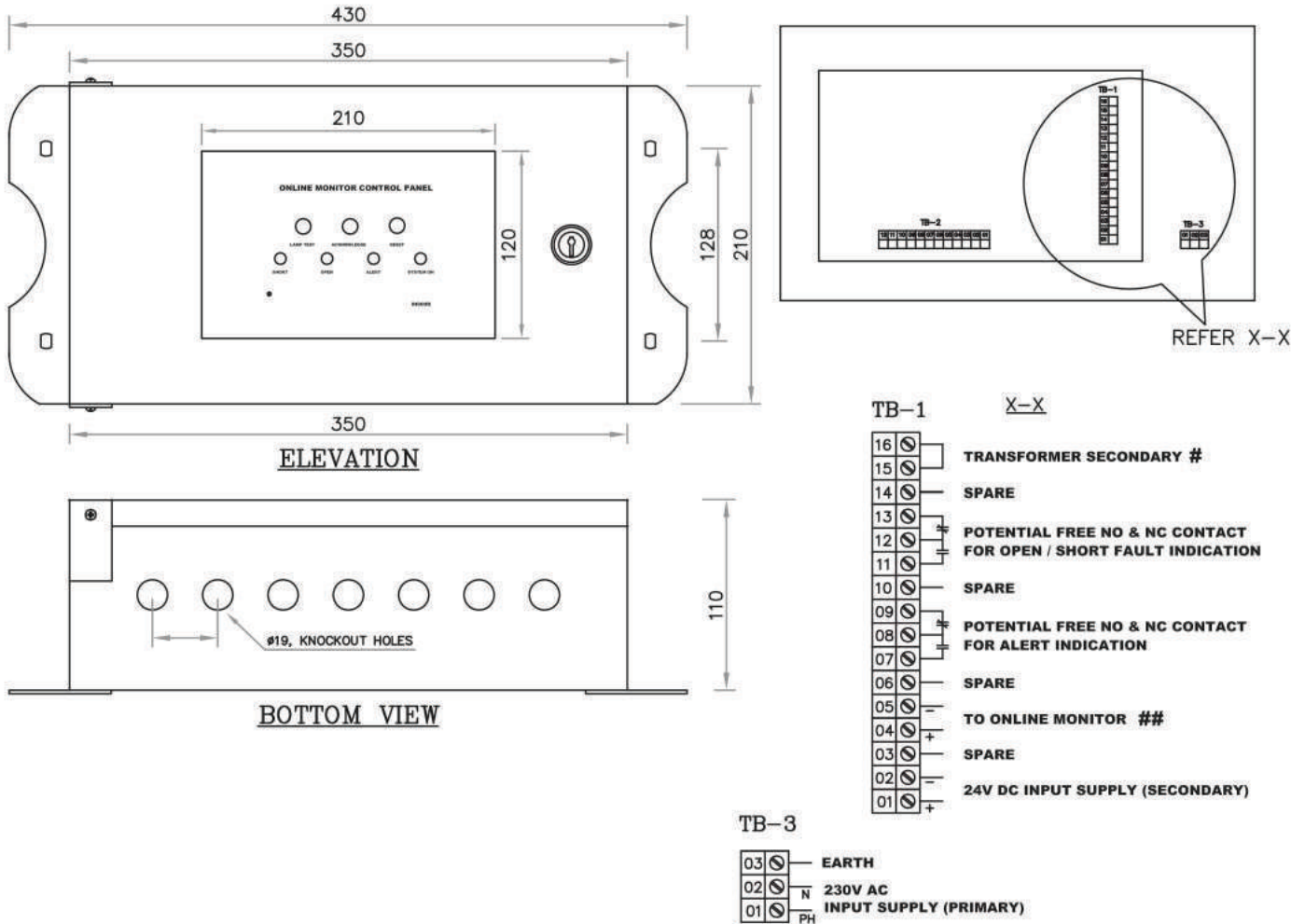

**Note:**

Online monitor control panel will be used to get alert indication signal from online monitor.  
One control panel can be used up to 25 Nos. of online monitors.

# High Pressure CO2 Fire Protection

## Online Monitor Control Panel - 2 Area

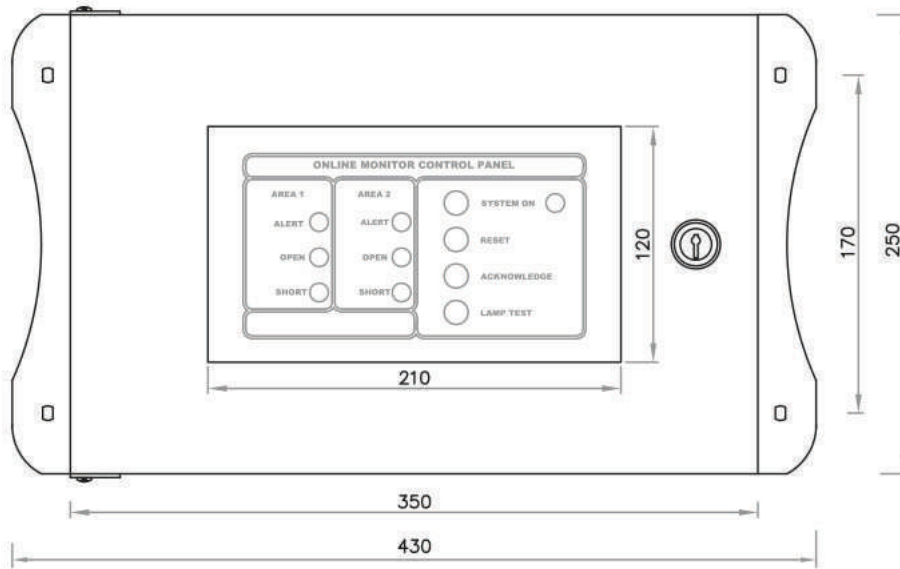

**ELEVATION**

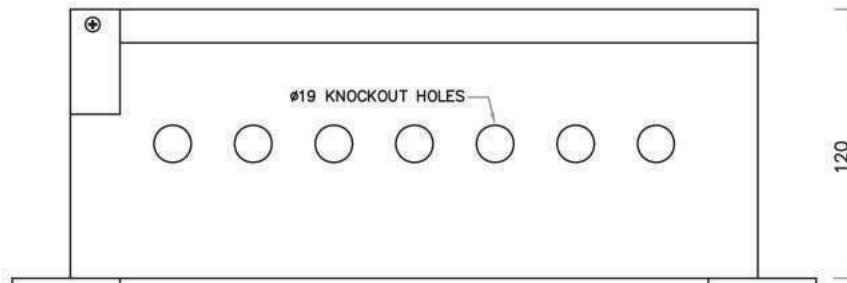

**BOTTOM VIEW**

### TERMINAL BLOCK DETAILS

#### TB-2

48	⊖	SPARE
47	⊖	FAH
46	⊖	EX
45	⊖	LWH
44	⊖	EX
43	⊖	SPARE
42	⊖	SPARE
41	⊖	COMMON FAULT
40	⊖	POTENTIAL FREE NO & NC OUTPUT
39	⊖	SPARE
38	⊖	ALERT INDICATION
37	⊖	POTENTIAL FREE NO & NC OUTPUT
36	⊖	ALERT INDICATION
35	⊖	GND
34	⊖	TO ONLINE MONITOR - AREA 2
33	⊖	SPARE
32	⊖	SPARE
31	⊖	ALERT INDICATION
30	⊖	POTENTIAL FREE NO & NC OUTPUT
29	⊖	ALERT INDICATION
28	⊖	SPARE
27	⊖	TO ONLINE MONITOR - AREA 1
26	⊖	SPARE
25	⊖	SPARE
24	⊖	SPARE
23	⊖	SPARE
22	⊖	24V DC BATTERY SUPPLY
21	⊖	SPARE
20	⊖	SPARE
19	⊖	SPARE
18	⊖	TRANSFORMER SECONDARY
17	⊖	TRANSFORMER SECONDARY

#### TB-3

3	⊖	EARTH
2	⊖	230V AC INPUT SUPPLY
1	⊖	230V AC INPUT SUPPLY

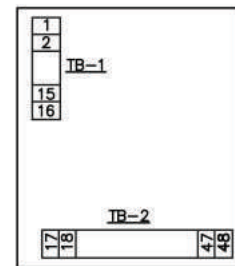

### Note:

Online monitor control panel will be used to get alert indication signal from online monitor.  
Two area control panel can be used up to 50 Nos. of online monitors.

## High Pressure CO2 Fire Protection

# Cylinder Weighing Counter Balance

Pieces required for Cylinder Weighing System

1	Pulley ø92	04-0700
2	Pulley ø62	04-0701
3	Metal ring for cylinder	04-0702
4	Pin	04-0703
5	Sleeve Pin	04-0704

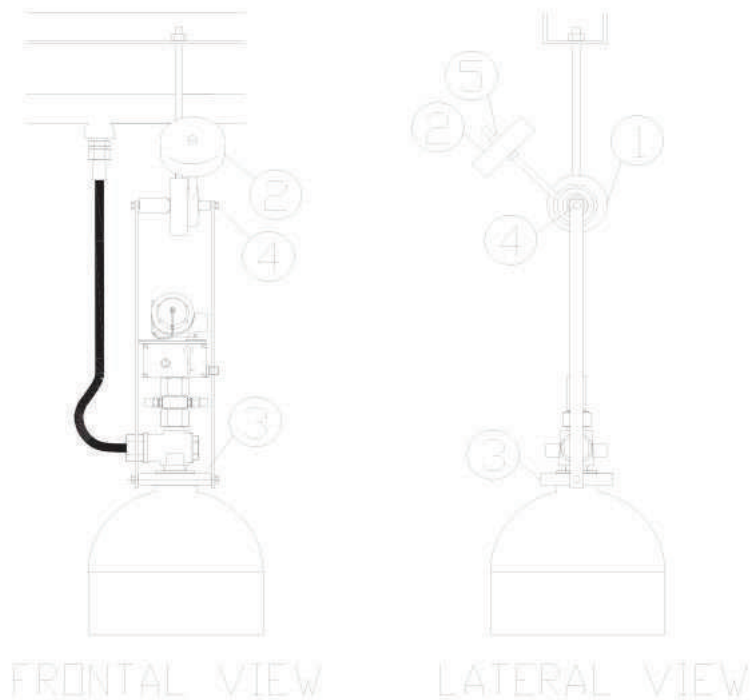

### P/N 06-0481

For each weighing control equipment check the right position of balancing weight.

To obtain this put a supplementary weight on the cylinder (i.e. a flange or similar) of about 4.5 Kg (10% of total weight of gas in the cylinder) and rotate the balancing weight to reach the upper position (the switch close).

Pull up the supplementary weight and check that the balancing weight goes down (the switch open).

Finally adjust the supplementary weight till its position will be higher then lock it with relevant nuts.

## High Pressure C02 Fire Protection

# Limit Switch For Counter Balance



Rated thermal current	1 th 10A
Rated insulation voltage	500V AC/DC
Protection against short-circuit	Fusibile/fuse 10A
Conductor section	1.5mmq
Current max. density	5A/mmq

### Features:

Honeywell explosion proof switches are designed specifically for use in hazardous location applications. The BX enclosure is sealed for protection against corrosion, water, dust and oil as defined in NEMA 1, 3, 4, 6, 7, 9 and 13 and IP67 as defined in IEC 529. These enclosures also meet the European Hazardous Locations Designation: EExd IIC T6 category II 2 GD, SIRA 00ATEX 1037X.

The entire series BX complies with the European Directive on Equipment and Protective Systems Intended for Use in Potentially Explosive Atmospheres (94/9/EC) commonly referred to as the ATEX Directive.

Compliance with the Essential Health and Safety Requirements has been assured by compliance with EN50014 1997 and EN50018 1994. BX with conduit types 1/2-14NPT, 3/4-14NPT also meet the North American Hazardous Locations Designation: Class I, Groups B, C and D; Class II, Groups E, F and G and comply with UL Standard: UL 894, CSA Standard: C22.2 No. 25-1966, C22.2 No. 30-M1986.

The BX is ideal for outdoor use or in adverse environments where a combination of explosion proof plus sealing requirements is needed.

To comply with explosion proof requirements the BX has flame paths within the housing, which cool exploding gases below the ignition temperature before they reach explosive gases surrounding the housing.

Flame paths on the BX are (1) an extended plunger between the switch cavity and head and (2) the cover-housing threads on the front of the switch.

## High Pressure CO2 Fire Protection

# Manually Actuated Ball Valve

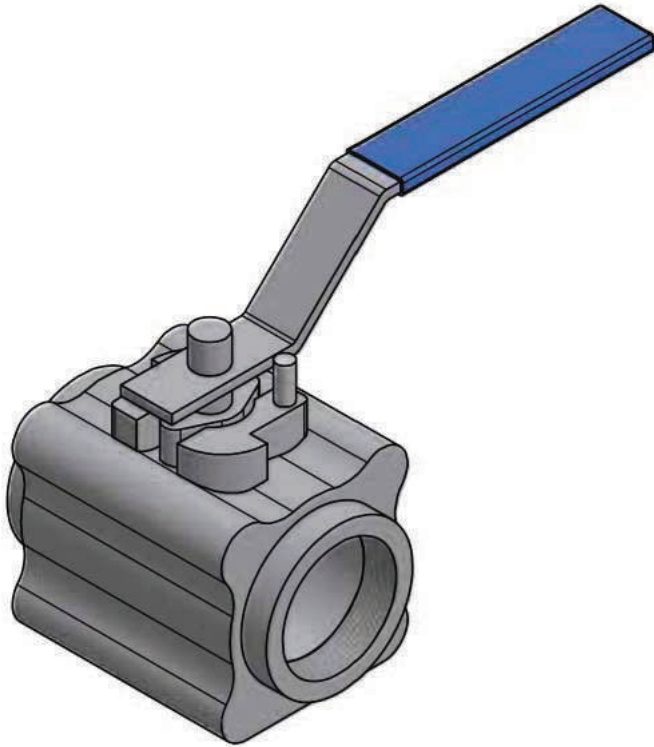

Manually actuated ball valves have ANSI Class 600 pressure ratings suitable for use as lockout/isolation valves in FM-200® and high-pressure or low-pressure carbon dioxide systems. They have a stainless steel ball and stem with either a coated carbon steel or stainless steel body as specified. Available valves sizes are 1/2 in (15 mm), 3/4 in (20 mm), 1 in (25 mm), 1 1/2 in (40 mm), or 2 in (50 mm). Each valve may be fitted with an optional limit switch and/or stem extension.

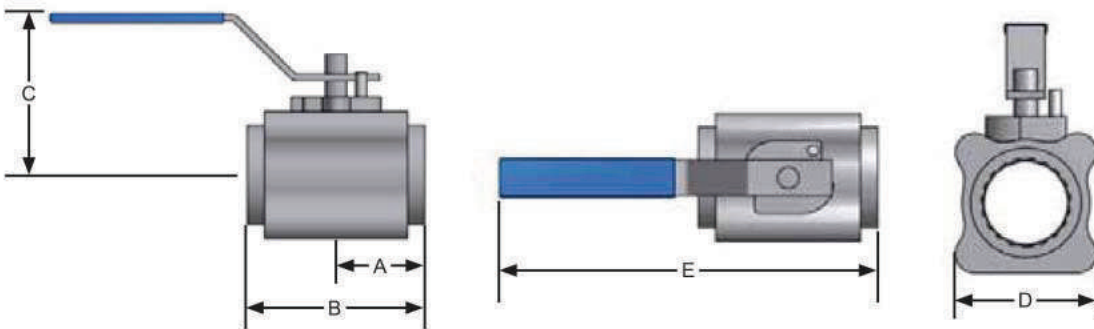

P/N	ValveSize		A		B		C		D		E	
	in	mm	in	mm	in	mm	in	mm	in	mm	in	mm
06-0731	1/2	15	1.29	33	2.59	66	2.36	60	2.06	52	5	127
06-0732	3/4	20	1.5	38	3.01	76	2.52	64	2.25	57	5	127
06-0733	1	25	1.85	47	3.69	94	3.29	84	2.59	66	7.5	191
06-0734	1 1/2	40	2.29	58	4.58	116	4.27	108	3.33	85	8.25	210
06-0735	2	50	2.55	65	5.11	130	4.46	113	3.66	93	8.25	210

## High Pressure CO2 Fire Protection

# Explosion Proof Pressure Switch



### **Explosion Proof Pressure Switch (P/N 06-0795)**

The 06-0795 Explosion-Proof Discharge Pressure Switch is used in potentially explosive atmospheres to send indication of agent discharge to a releasing panel and/or initiate the shut down of equipment that may deplete agent concentration. It is a single pole, double throw (SPDT) switch with contacts rated 15 Amps at 125/250/480 VAC resistive.

### **Specifications**

Certification: Class I, Div 1 & 2, Groups B, C, & D.  
Class I, Class II, Div 1 & 2, Groups E, F & G,  
Class III, and Class I, Zone 1, Group IIB+H2 T6  
II 2 G EEx d IIC T6, I 2 D T+85°C, Tamb = -40°C to +71°C, IP 66

Enclosure: Die cast aluminum, epoxy powder coated; gasketed; coverlock;  
internal set point lock standard. NEMA 4X

Switch Output: SPDT

Electrical Connection: Two 3/4" (20 mm) NPT E/C; terminal block standard

Pressure Connection: 1/2" (15 mm) FNPT

Adjustable Set Point Range: 15 to 300 psi (1.0 to 20.7 bar) Preset to 30 psi (2.1 bar) rise

Max Pressure: 2500 psi (172.4 bar)

# High Pressure C02 Fire Protection Pneumatic Time Delay

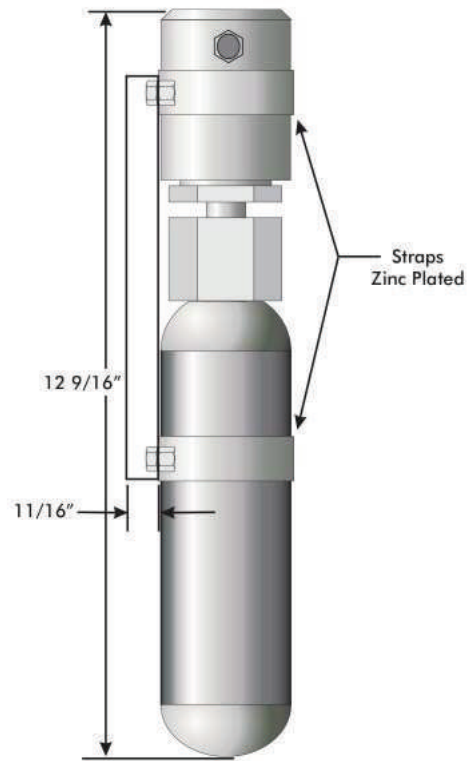
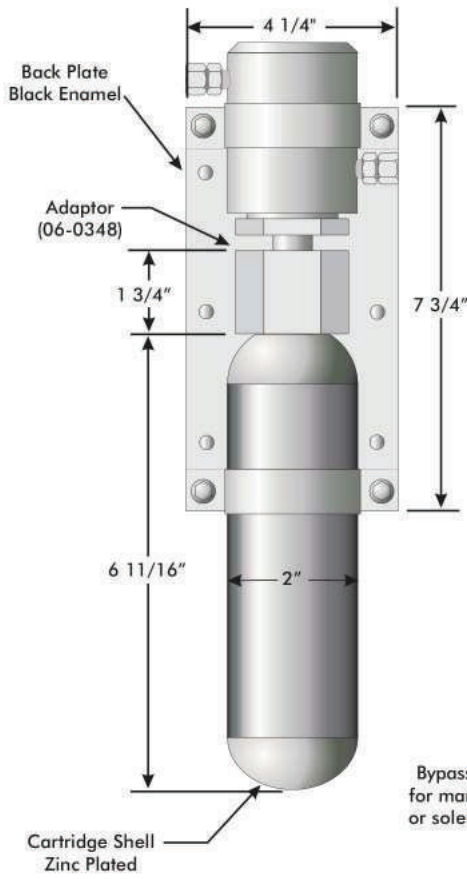

**P/N 06-0345**

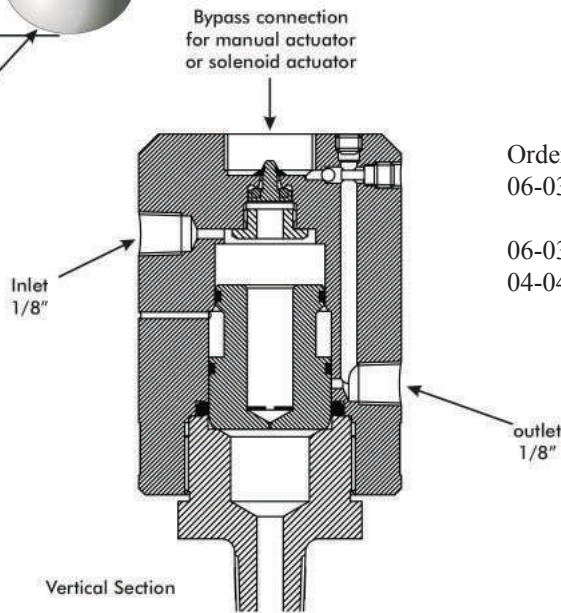

## Ordering Information

- 06-0345 Pneumatic Time Delay c/w wall straps (add manual actuator 06-0348 as required).
- 06-0348 Manual Actuator, brass, for 06-0345
- 04-0499 Pneumatic Adaptor for 06-0348

# High Pressure CO<sub>2</sub> Fire Protection

## Ordering Information

### Carbon Dioxide Cylinder Assemblies

*Includes cylinder, Brass SW-50 Valve, siphon tube, and carbon dioxide*

06-0261	50 lb capacity, master
06-0260	75 lb capacity, master
06-0241	100 lb capacity, master
06-0240	100 lb capacity, slave

### Cylinder Valve Actuators

06-0235	Manual/Pneumatic Actuator, Nickel Plated
04-0099	Connecting Link, Nickel Plated
06-0236	Solenoid Valve Kit, 24 VDC Standard
06-0653	Solenoid Valve Kit, 24 VDC Explosion-proof
06-0238	Solenoid Valve Kit, 12 VDC Standard
06-0239	Solenoid Valve Kit, 120 VAC Standard

### Cylinder Mounting Straps

04-0147	Single cylinder strap for 50 lb unit
04-0309	Single cylinder strap for 75 lb unit
04-0148	Single cylinder strap for 100 lb unit

### Accessories

06-0237	Discharge Bend & Check Valve Assembly for SW-50 cylinder valves
06-0242	Discharge Bend c/w Discharge Adapter for SW-50 cylinder valves
04-0299	Discharge Adapter for SW-50 Valve

### Nozzles

06-0358	1/2 inch, 360°, brass
06-0358	1/2 inch, total flooding, side wall, brass
06-0360	1/2 inch, vent type
06-0291	1/2 inch, local application, 'S' nozzle nickel plated
06-0353	Flange & seal set for "S" nozzle

### Directional & Check Valves

06-0755	Selector Valve, 1/2 inch, screwed
06-0756	Selector Valve, 3/4 inch, screwed
06-0757	Selector Valve, 1 inch, screwed
06-0778	Selector Valve, 1-1/2 inch, screwed
06-0759	Selector Valve, 2 inch, screwed
20480482	Actuation Kit for Selector Valves with manual actuation.
06-0347	Selector/Stop Valve, 1/2"-3/4" brass, R1 type
06-0140	Check Valve, 1/2 inch
06-0328	Check Valve, 3/4 inch
06-0327	Check Valve, 1 inch
06-0326	Check Valve, 1-1/4 inch

06-0635	Check Valve, 1-1/2 inch
06-0636	Check Valve, 2 inch
06-0637	Check Valve, 3 inch

### Auxiliary Equipment

06-0246	Pressure Release Trip
06-0247	Pressure Operated Switch (in pipe)
06-0275	CO <sub>2</sub> Operated Siren
06-0276	Manifold/Header Safety, 1/2 inch, brass
04-0343	Bleeder Valve, 1/2" for joint systems
06-0345	Pneumatic Time Delay c/w wall straps
06-0348	Manual Actuator, brass, for 06-0345 & 06-0347
04-0499	Pneumatic Adapter for 06-0348
09-0003	Manual Discharge Station (Electric)
09-0005	Change-Over Switch
12-0050	Door Warning Sign, English
12-0057	Door Warning Sign, French

### Cylinder Valves

06-0232	SW-50S Slave Valve, brass
06-0233	SW-50M Master Valve, brass

### Remote Cable Control

01-0005	1/16" Stainless Steel Cable (price per foot)
04-0012	Cable Clamp for 1/16" Cable
06-0245	Corner Pulley (90 degree)
06-0259	Latch Type Pull Box c/w cable nipple
06-0248	Conduit Bracket
06-0258	2/1 Cable Junction Box

### Copper Tubing And Brass Fittings

08-0018	Tube, 3/16" OD x 0.032" wall, soft copper (50 foot coil)
08-0007	Connector, 1/8" NPTM x 3/16" tube
08-0016	Bushing, 3/8" NPTM x 1/8" NPTF
08-0031	Elbow, 1/8" NPTM x 3/16" tube
08-0039	Elbow, 3/16" x 3/16" tube
08-0096	Elbow, Street 3/8" NPTM x 3/8" NPTF
08-0097	Elbow, Street 3/8" NPTM x 1/2" NPTF
08-0015	Tee, 3/16" x 3/16" x 3/16" tube
08-0065	Union, 3/16" x 3/16" tube
08-0066	Bleed Valve, 1/8" NPTF ends

### Pipe Fittings, Steel Mi

08-0082	Elbow, street 3/8" NPTM x 3/8" NPTF
08-0081	Elbow, Street 3/4" NPTM x 3/4" NPTF

### Manuals

50-0019	Installation & Maintenance Manual
---------	-----------------------------------